

Unimaster Dust Collectors

Series UMA 70-250

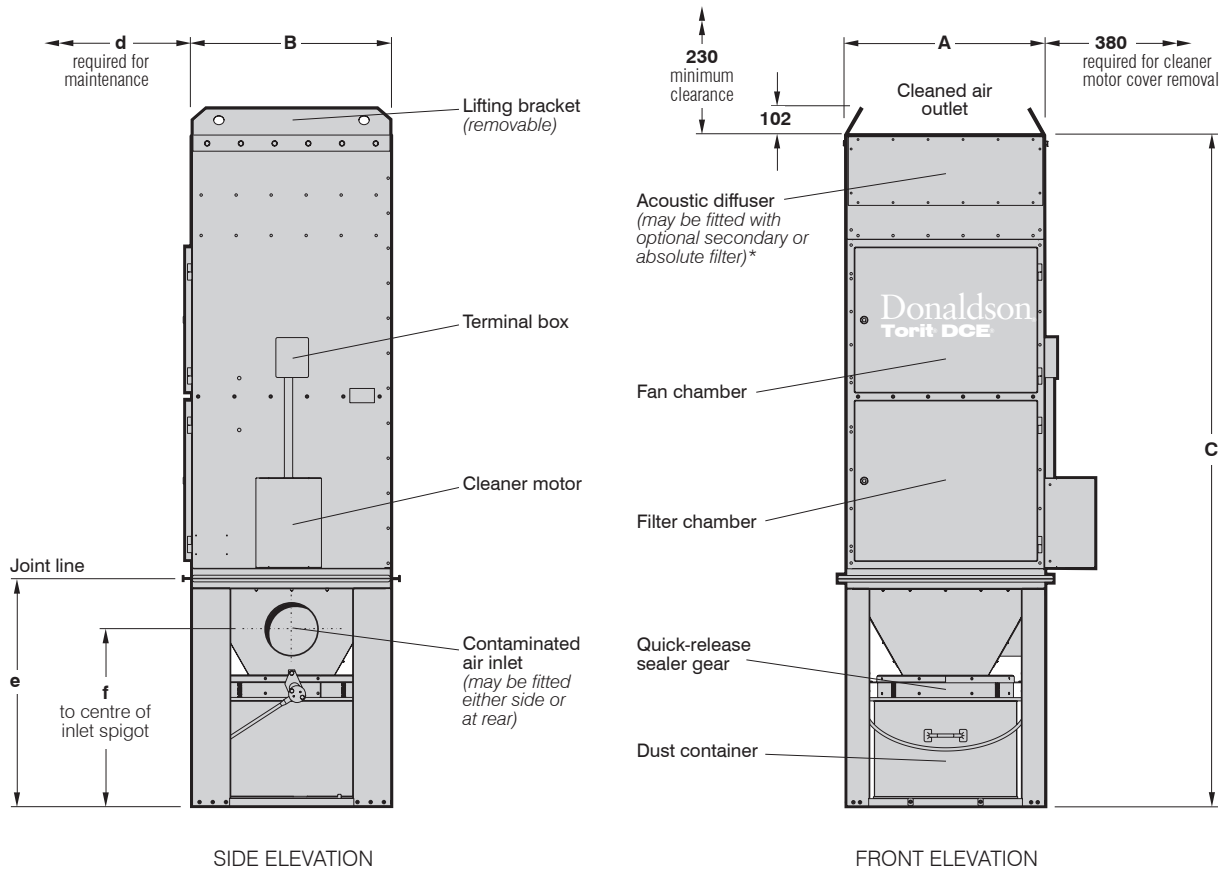

UNIMASTER DUST COLLECTOR WITH DUST CONTAINER

UMA 153 illustrated. Suitable for inside locations. *Secondary filter and absolute filter not available for UMA 72 dust collector.

SPECIFICATION

Type	Filtration area	DIMENSIONS in mm						Inlet spigot (inside dia.) mm	Fan	Motor rating	Dust container	Net weight (approx.)		
		A	B	C	d	e	f							
UMA 72	6.23 m ³	575	575	2000	600	729	648	Ø 101	G1	0.75 kW	55 litre	203 kg		
UMA 103	9.29 m ³	765	575	2395	800	843	685	Ø 203	G1	0.75 kW	80 litre	295 kg		
									K3	1.50 kW			300 kg	
									K3	1.50 kW				
UMA 153	13.94 m ³	765	765	2530	800	843	685	Ø 203	KV5	2.20 kW	80 litre	353 kg		
									KV7	3.00 kW			378 kg	
									G8	5.50 kW				393 kg
									K3	1.50 kW			80 litre	
UMA 253	22.67 m ³	1146	765	2880	1150	1059	883	Ø 254	KV5	2.20 kW	80 litre	465 kg		
									KV7	3.00 kW				190 kg
									G8	5.50 kW			505 kg	

Unimaster Dust Collectors – Series UMA 70-250

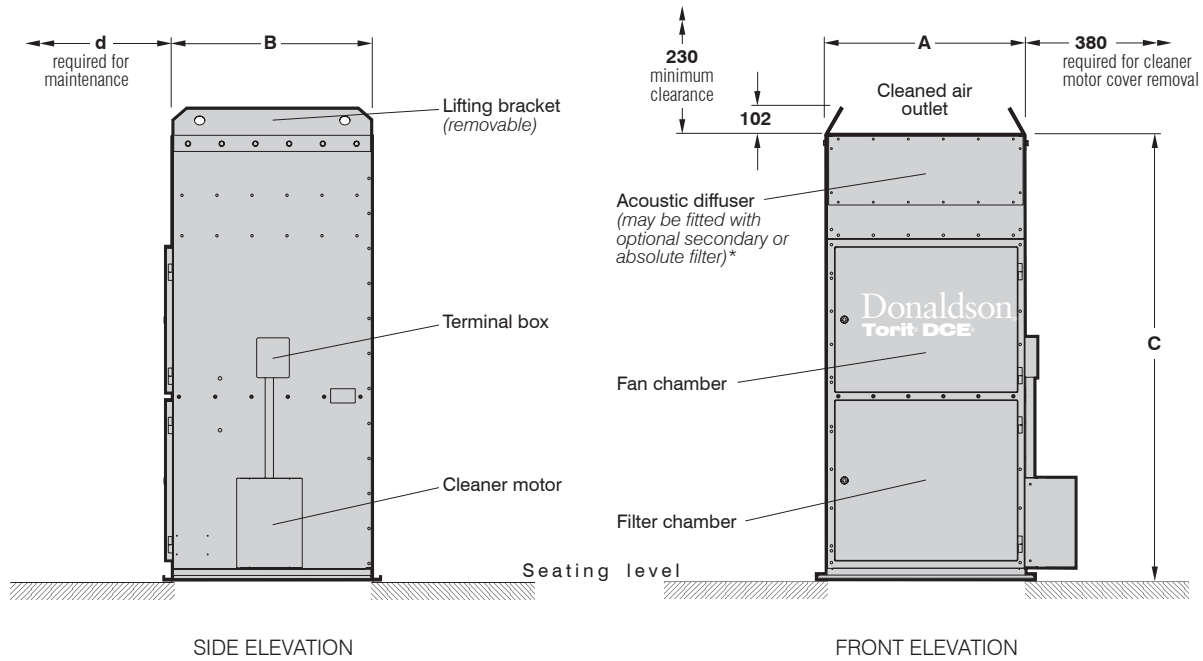

UNIMASTER HOPPER TYPE DUST COLLECTOR

UMA 150H illustrated. Suitable for inside locations. *Secondary filter and absolute filter not available for UMA 70H dust collector.

SPECIFICATION								
Type	Filtration area	DIMENSIONS in mm				Fan	Motor rating	Net weight (approx.)
		A	B	C	d			
UMA 70H	6.23 m ³	575	575	1270	600	G1	0.75 kW	170 kg
UMA 100H	9.29 m ³	765	575	1590	800	G1	0.75 kW	235 kg
UMA 150H	13.94 m ³	765	765	1725	800	K3	1.50 kW	275 kg
						KV5	2.20 kW	290 kg
						KV7	3.00 kW	315 kg
						G8	5.50 kW	330 kg
UMA 250H	22.67 m ³	1146	765	1860	1150	K3	1.50 kW	360 kg
						KV5	2.20 kW	375 kg
						KV7	3.00 kW	400 kg
						G8	5.50 kW	415 kg

DUST CONTAINER			Typical dust densities	
Size	Approx net weight	Dust	Density with 50% voidage	
55 litre (2 cu.ft.)	5 kg	Sander	0.13 kg/litre	
80 litre (3 cu.ft.)	6 kg	Graphite	0.80 kg/litre	
A reasonable total load for removal by hand would be 25 kg		Sand	1.33 kg/litre	
		Iron	3.58 kg/litre	
		Steel	3.72 kg/litre	

Unimaster Dust Collectors – Series UMA 70-250

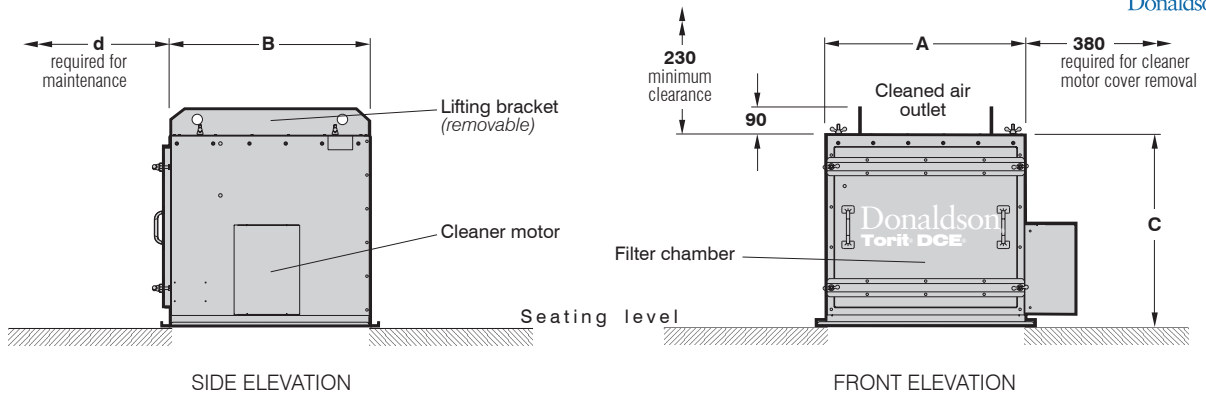

UNIMASTER VENTING TYPE DUST COLLECTOR

UMA 150V illustrated. Suitable for inside locations and outside when fitted with optional weather cowl.

SPECIFICATION						
Type	Filtration area	DIMENSIONS in mm				Net weight (approx.)
		A	B	C	d	
UMA 70V	6.23 m ³	575	575	678	560	93 kg
UMA 100V	9.29 m ³	765	575	678	560	114 kg
UMA 150V	13.94 m ³	765	765	735	760	135 kg
UMA 250V	22.67 m ³	1146	765	735	760	175 kg

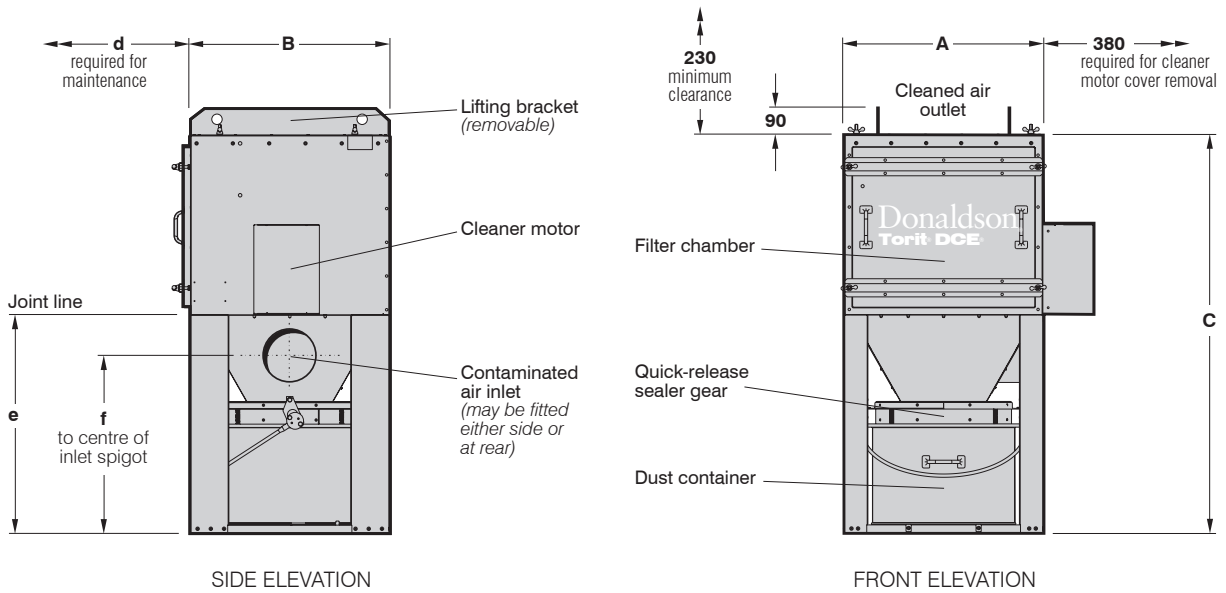

UNIMASTER VENTING TYPE DUST COLLECTOR WITH DUST CONTAINER

UMA 153V illustrated. Suitable for inside locations and outside when fitted with optional weather cowl.

SPECIFICATION										
Type	Filtration area	DIMENSIONS in mm						Inlet spigot (inside dia.) mm	Dust container	Net weight (approx.)
		A	B	C	d	e	f			
UMA 72V	6.23 m ³	575	575	1369	560	729	648	∅ 101	55 litre	126 kg
UMA 103V	9.29 m ³	765	575	1485	560	845	685	∅ 203	80 litre	174 kg
UMA 153V	13.94 m ³	765	765	1542	760	845	685	∅ 203	80 litre	199 kg
UMA 253V	22.67 m ³	1146	765	1758	760	1061	883	∅ 254	80 litre	265 kg

Unimaster Dust Collectors – Series UMA 70-250

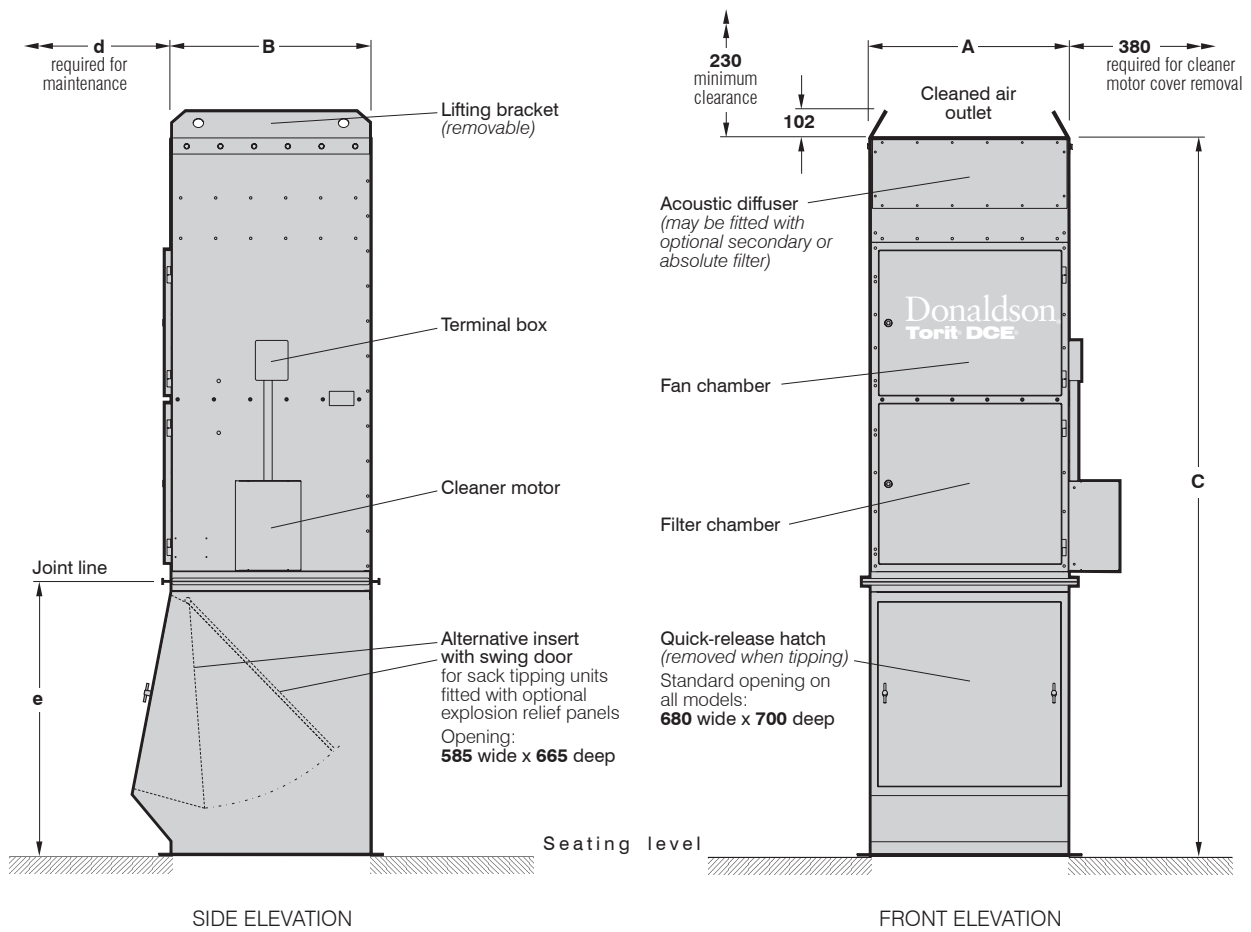

UNIMASTER SACK TIPPING UNIT
 UMA 150STU illustrated. Suitable for inside locations.

SPECIFICATION									
DIMENSIONS in mm									
Type	Filtration area	A	B	C	d	e	Fan	Motor rating	Net weight (approx.)
UMA 100STU	9.29 m ³	765	575	2706	800	1054	K3	1.50 kW	313 kg
UMA 150STU	13.94 m ³	765	765	2762	800	1054	K3	1.50 kW	368 kg
UMA 250STU	22.67 m ³	1146	765	2897	1150	1054	K3	1.50 kW	553 kg

DESIGN LIMITS (standard equipment)	
Temperature range	-10° to +60°C
Pressure limits:	Collectors with fan: as fan performance curves from shut-off to operating pressure Venting type collectors: -300 mm W.G. to +250 mm W.G.
Dimension tolerances:	±3 mm on main dimensions; ±2 mm on detail dimensions

DIMENSIONS in mm			
Type	A	B	c
UMA 70	225	225	116
UMA 100	295	250	116
UMA 150	320	320	116
UMA 250	340	340	403

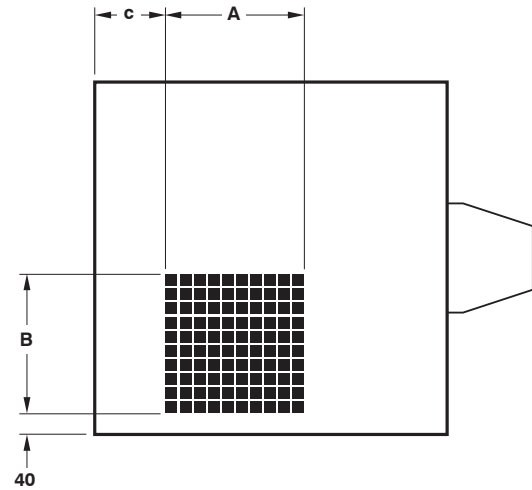

CLEANED AIR OUTLET DETAILS
UMA 150 illustrated

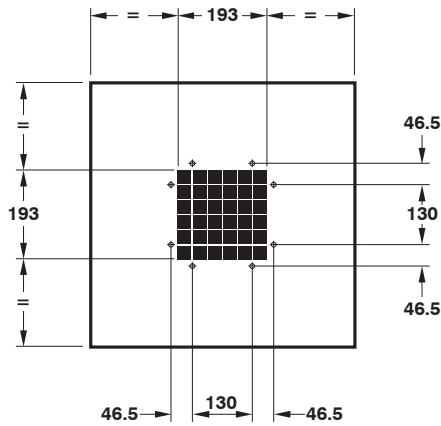

UMA 70V

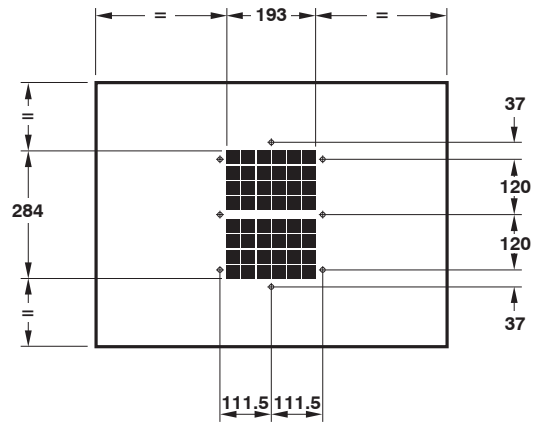

UMA 100V and 150V

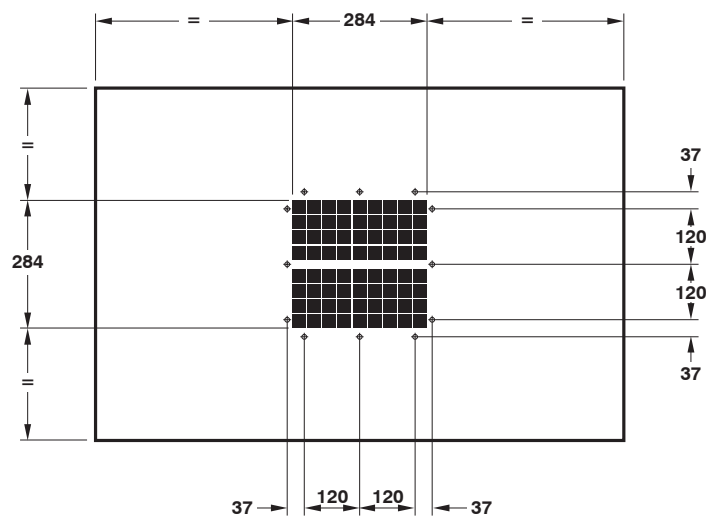

UMA 250V

CLEANED AIR OUTLET DETAILS FOR VENTING TYPE COLLECTORS
All holes \varnothing 4 mm

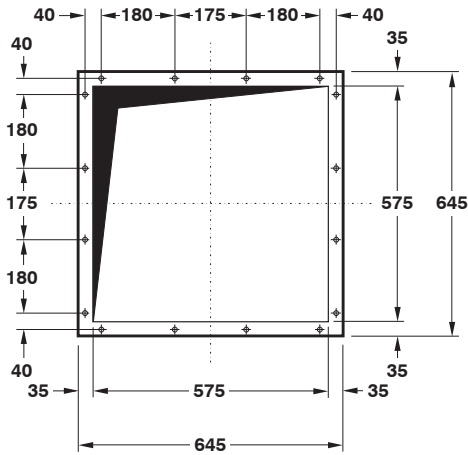

UMA 70H and 70V

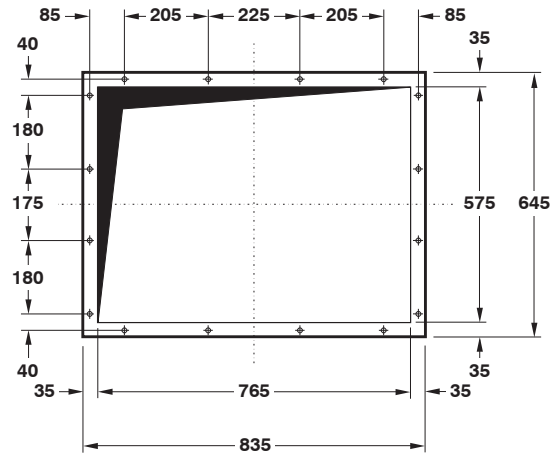

UMA 100H and 100V

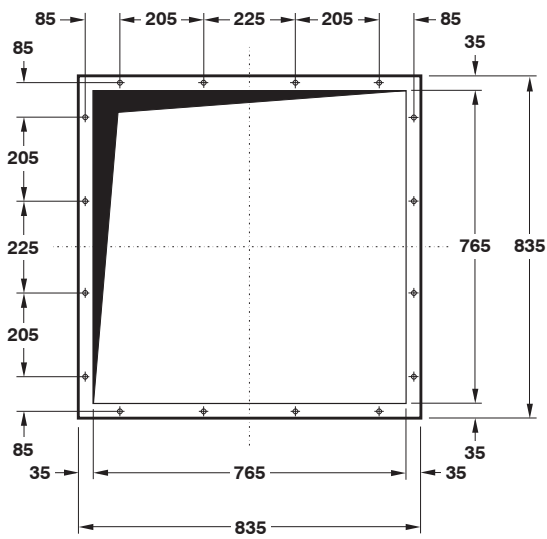

UMA 150H and 150V

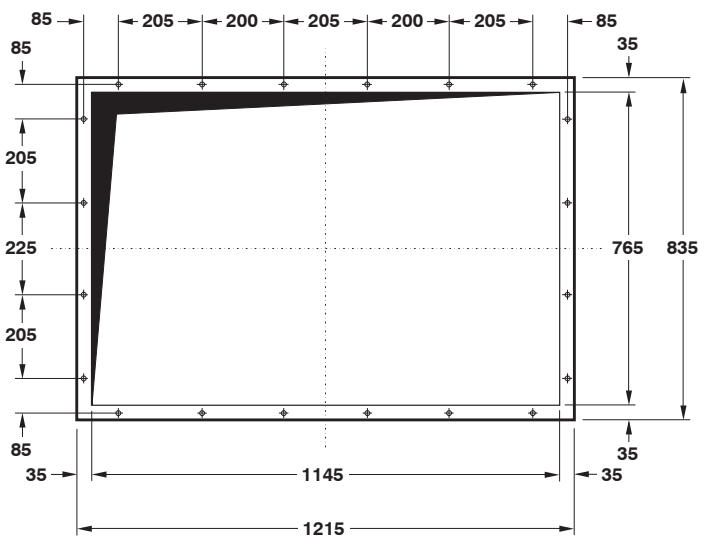

UMA 250H and 250V

APERTURE AND MOUNTING FLANGE DETAILS FOR HOPPER AND VENTING TYPE COLLECTORS

All holes $\varnothing 12$ mm for M10 bolts

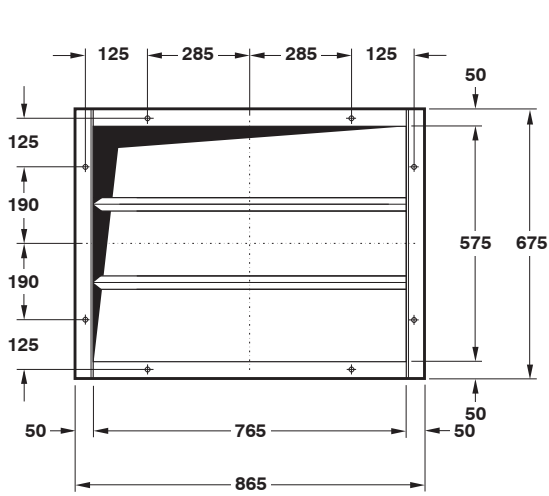

UMA 100STU

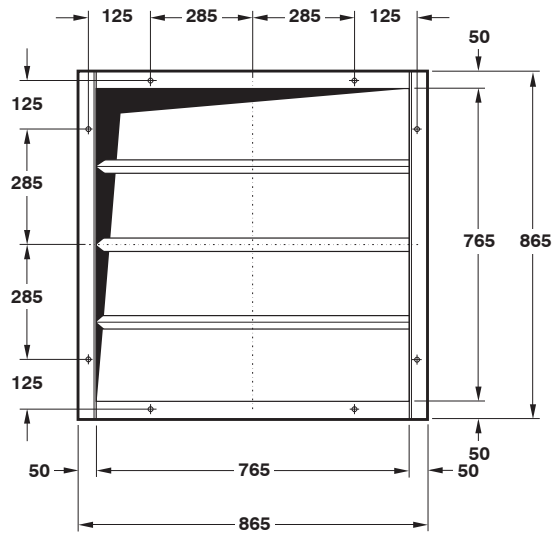

UMA 150STU

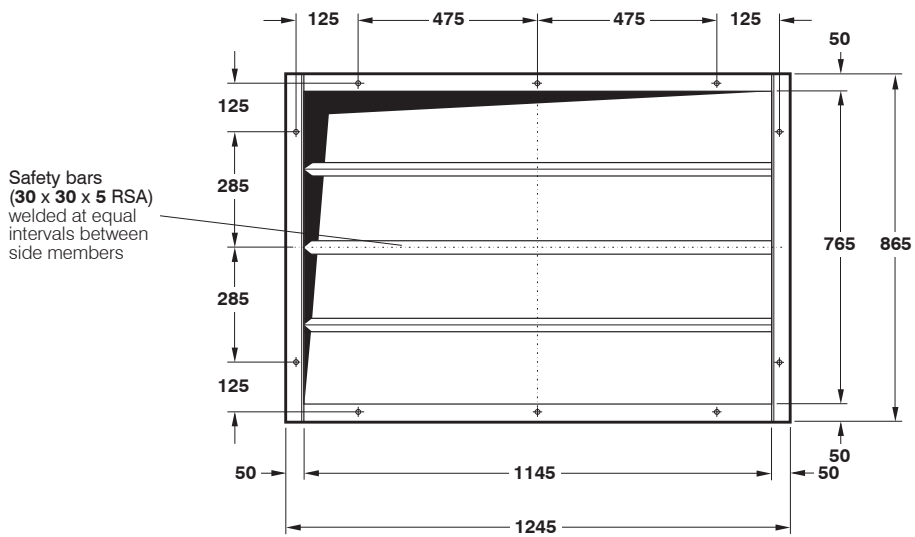

UMA 250STU

APERTURE AND MOUNTING FLANGE DETAILS FOR SACK TIPPING UNITS

All holes $\varnothing 12$ mm for M10 bolts

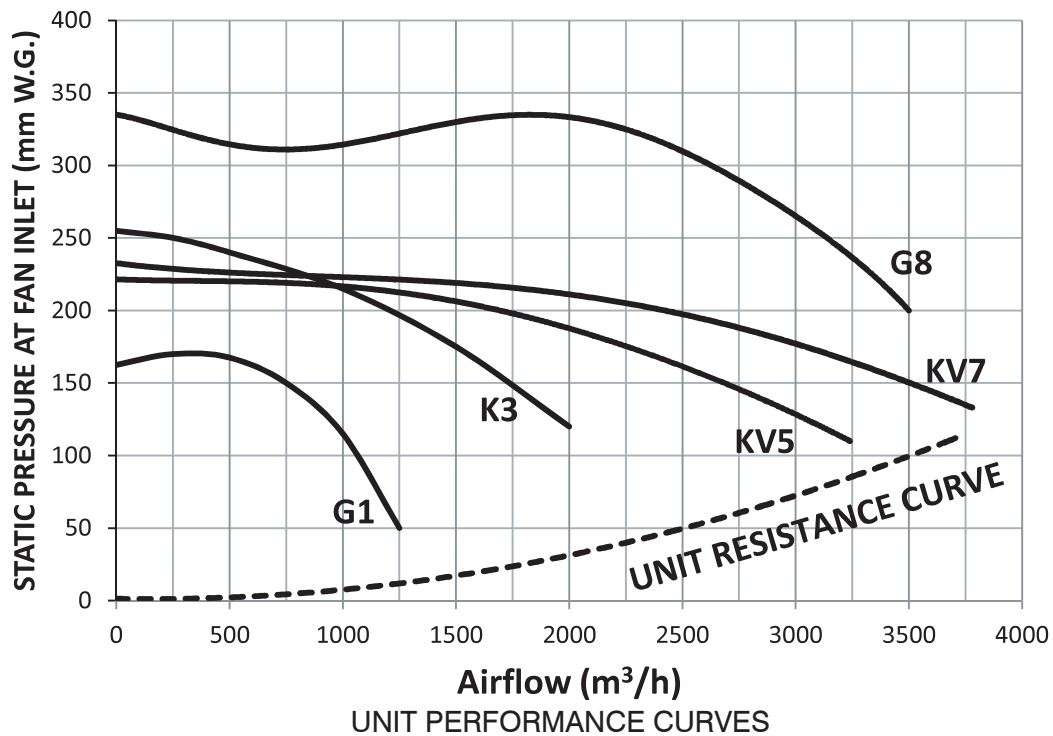

FAN SELECTION

These curves indicate static pressure available at fan inlet for a given volume when fitted inside a Unimaster dust collector.

To select the most suitable fan for a given application:

- 1 Determine the air volume, in m³/h, needed to entrain the dust.
- 2 Read off the unit resistance, in mm W.G., at air volume required.
- 3 Assess pressure drop over filter bags prior to cleaning, usually 50 to 100 mm W.G.
- 4 Estimate pressure drop through connected system – i.e. between point of entrainment and collector inlet.
- 5 The sum of **2**, **3** and **4** = W.G. required.
- 6 Consult graph for fan performances available.

Sack Tipping Units have K3 (1.5 kW) fans with modified outlet to ensure adequate face velocities at the tipping hatch under normal operating conditions. Typically, the exhaust rate for the UMA 250STU is 1275 m³/h (750 cfm).

ELECTRICAL REQUIREMENTS

UCS Controller

Voltage input: 220-240V, Single Phase, 50Hz (for collectors with G1 or K3 fans only)
 218-242V / 380-420V, Three Phase, 50Hz
 250-277V / 440-480V, Three Phase, 60Hz
 or to suit local voltage

Unimaster Dust Collectors – Series UMA 70-250

NOISE LEVELS

Machinery noise levels are an important consideration in the design and selection of new equipment. Several EC Directives and National Laws/Regulations adopting these directives make reference to airborne noise emissions. Actions that employers are required to comply with if employees are subjected to a daily personal noise exposure $L_{ep,d}$ of 80 dB(A) or more are also specified.

All Unimaster dust collectors, when fitted with an acoustic diffuser, secondary filter or absolute filter, operating an 8 hour shift, are below this action limit.

WEIGHTED SOUND PRESSURE LEVELS

All readings were taken in normal industrial areas, i.e. semi-reverberant surroundings, with local equipment silent. Measurements were taken at maximum air flow conditions at 1.0 metre radius from the equipment housing and 1.6 metres above base level, using a precision sound level meter and octave filter.

	G1	K3	KV5	KV7	G8
With acoustic diffuser	65 dB(A)	67 dB(A)	69 dB(A)	69 dB(A) [†]	72 dB(A)
With secondary filter	–*	67 dB(A)	69 dB(A)	69 dB(A)	72 dB(A)
With absolute filter	–*	67 dB(A)	69 dB(A)	69 dB(A)	72 dB(A)

Noise levels of installed equipment may vary due to site conditions.
 *Secondary and absolute filter not supplied with G1 fan. [†]Measured data.

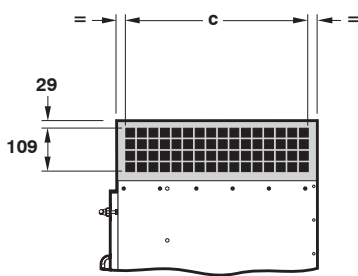

SIDE ELEVATION
 (Detail of cleaned air outlet with weather cowl and lid removed)

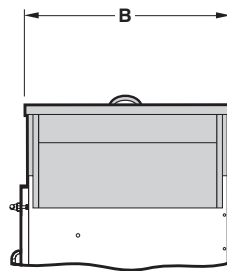

SIDE ELEVATION

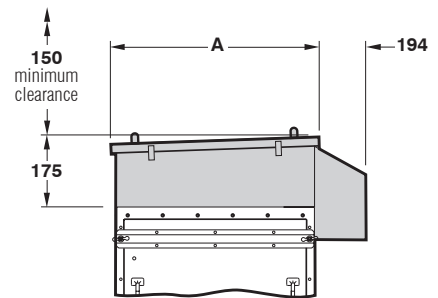

FRONT ELEVATION

OPTIONAL WEATHER COWL
 UMA 150V illustrated

SPECIFICATION

Type	DIMENSIONS in mm			Net weight (approx.)
	A	B	c	
UMA 70V	585	584	473	12 kg
UMA 100V	775	584	473	12 kg
UMA 150V	775	774	697	19 kg
UMA 250V	1156	774	697	19 kg

Unimaster Dust Collectors – Series UMA 70-250

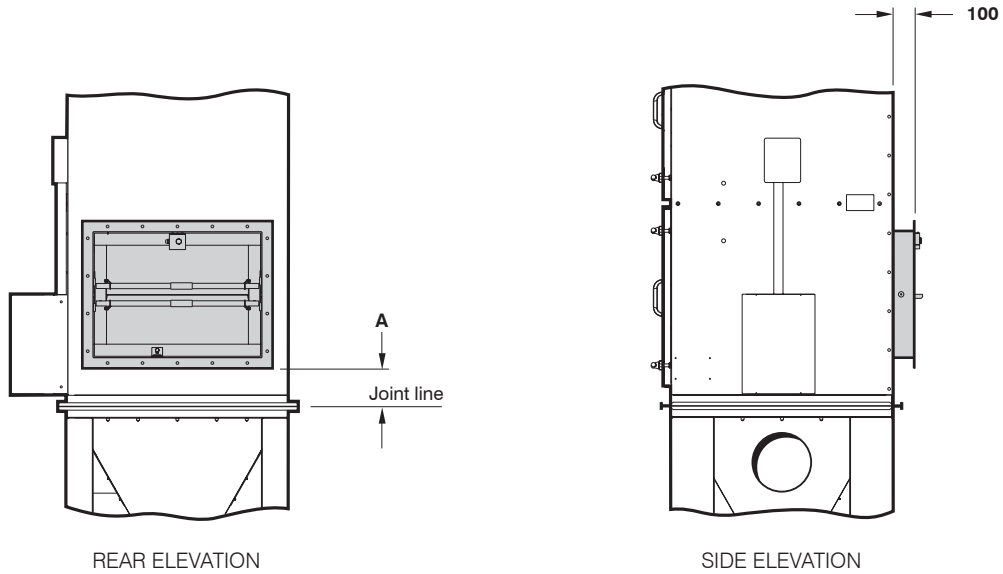

POSITION OF OPTIONAL EXPLOSION RELIEF FLANGE
UMA 153 illustrated

UMA type	72	103	153	253	70H	100H	150H	250H	70V	100V	150V	72V	103V	153V	253V
Dimension A in mm:	76	114	171	105	114	114	171	105	114	114	171	105	75	133	67

If a vent duct is not connected to the explosion relief flange, then a minimum clearance of 500 mm should be made to the rear of the collector to ensure efficient operation of the explosion venting process. Consideration should be given to the local surrounding area in regards to the pressure and flame effects.

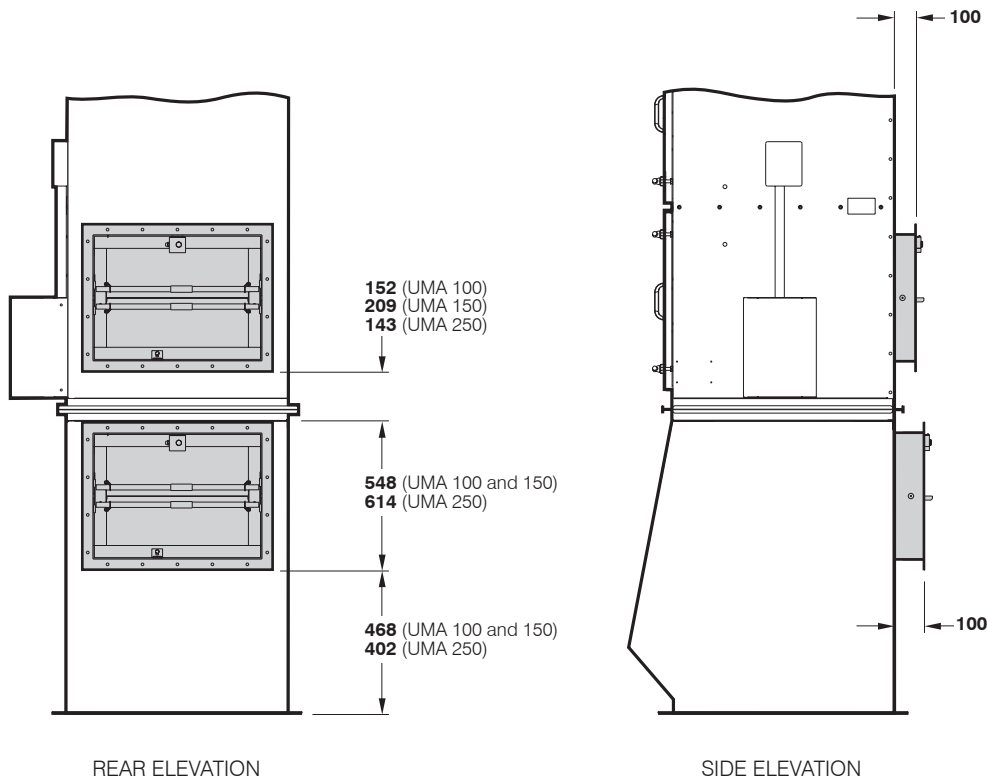

POSITION OF OPTIONAL EXPLOSION RELIEF FLANGES FOR SACK TIPPING UNITS
UMA 150STU illustrated

If vent ducts are not connected to the explosion relief flanges, then a minimum clearance of 500 mm should be made to the rear of the collector to ensure efficient operation of the explosion venting process. Consideration should be given to the local surrounding area in regards to the pressure and flame effects.

Unimaster Dust Collectors – Series UMA 70-250

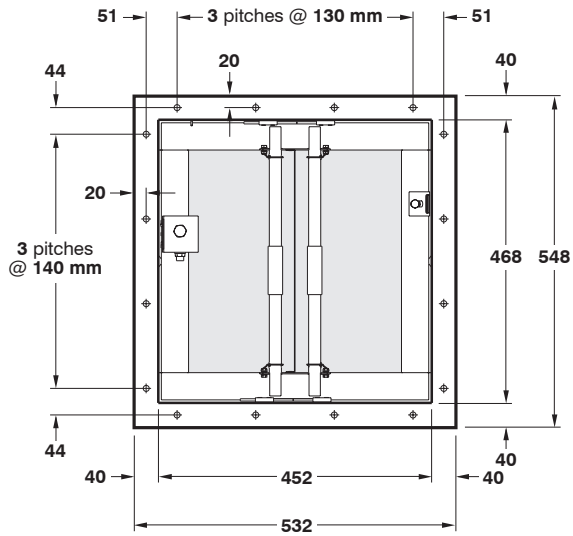

UMA 70

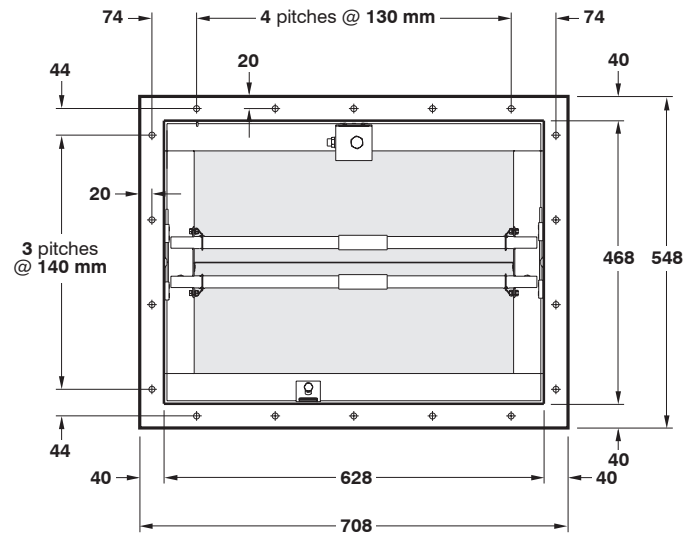

UMA 100 and 150

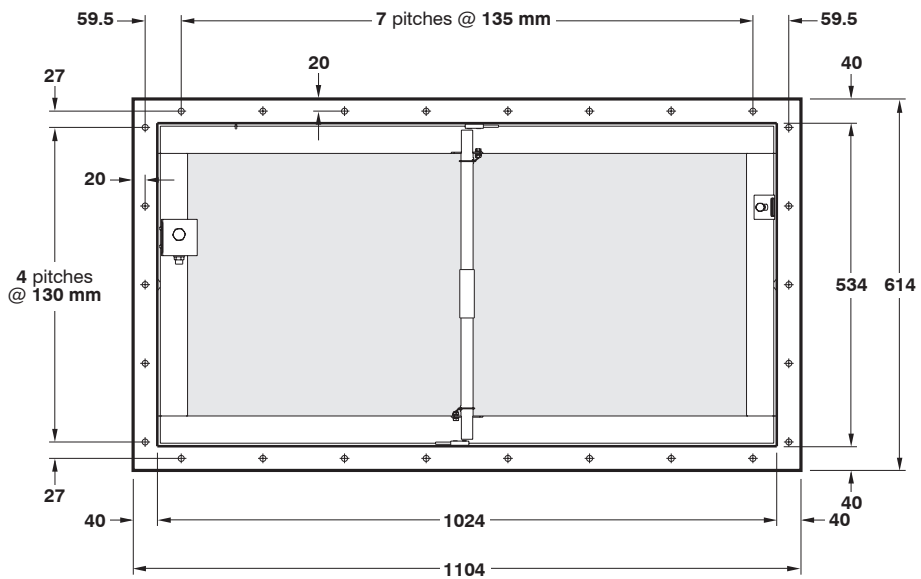

UMA 250

OPTIONAL EXPLOSION RELIEF FLANGE MOUNTING DETAILS

All vertical holes drilled $\varnothing 10$ mm for M8 bolts. All horizontal holes threaded to accept M8 bolts.

