



SP80/90

Max Flow: 100 gpm (379 lpm)



SP80/90 Spin-On Filters

Working Pressures to:

150 psi / 1035 kPa / 10.3 bar

Rated Static Burst to:

250 psi / 1725 kPa / 17.2 bar

Flow Range To:

100 gpm / 379 lpm

Features

SP80/90 double filter head allows for double the flow capacity, with two filters to hold more contaminant. Aluminum casting and nitrile seals standard. SP80/90 filters are interchangeable with SP50/60 filters.

Beta Rating

- Performance to $\beta_{<40} = 1000$

Porting Size Options

- 1½" NPT
- SAE-24 O-Ring
- 2" SAE 4-Bolt Flange Code 61

Replacement Filter Lengths

- 6.7" / 170mm
- 7.0" / 178mm
- 10.7" / 271mm

Standard Bypass Ratings

- 25 psi / 172.5 kPa / 1.72 bar
- 15 psi / 103.4 kPa / 1.34 bar
- 5 psi / 34.5 kPa / .34 bar
- no bypass

Applications

- Fluid Conditioning Systems
- In-Plant Systems
- Mobile Equipment
- Power Transmissions
- Process Systems



Assembly Weight

- 10.0 lbs / 4.5 kg (short) - approximate
- 11.8 lbs / 5.4 kg (long)

Operating Temperatures

- -22°F to 225°F / -30°C to 107°C

Filter Collapse Ratings

- 100 psid / 690 kPa / 6.9 bar

SP80/90 Specification Illustrations

ASSEMBLY - SIDE VIEW

All dimensions are shown in inches [millimeters].

Combination

**1½" NPT and 2" SAE 4-Bolt Flange (Both Ends)
or SAE-24 (Both Ends)**

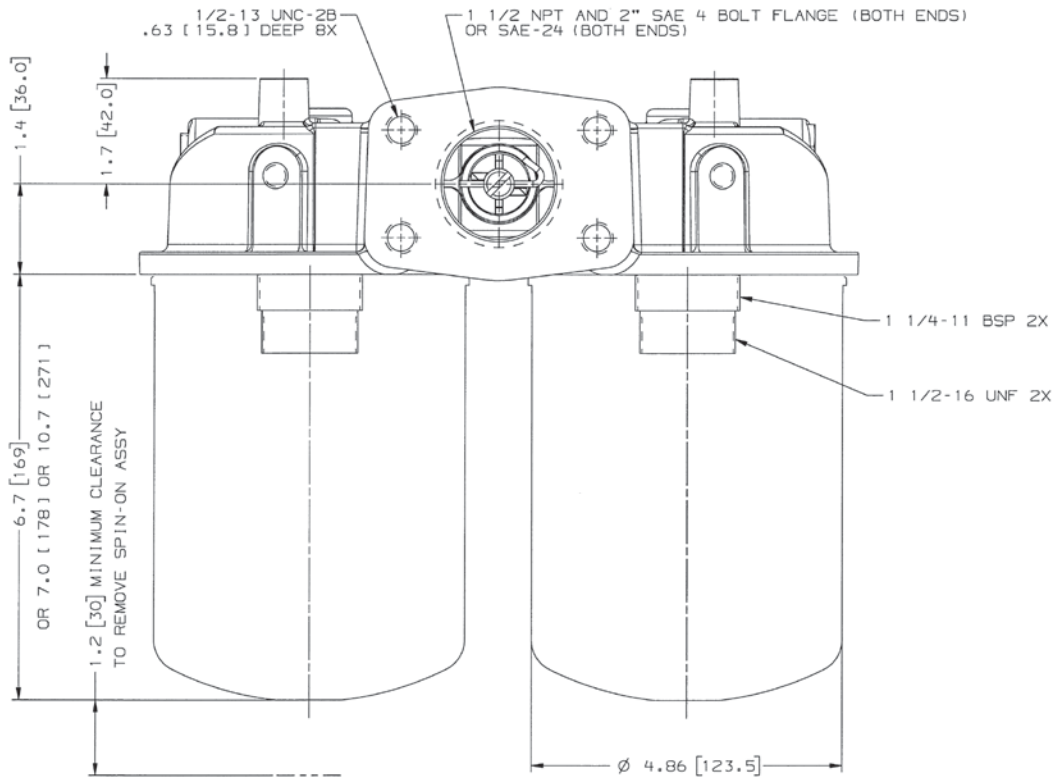

HEAD - TOP VIEW

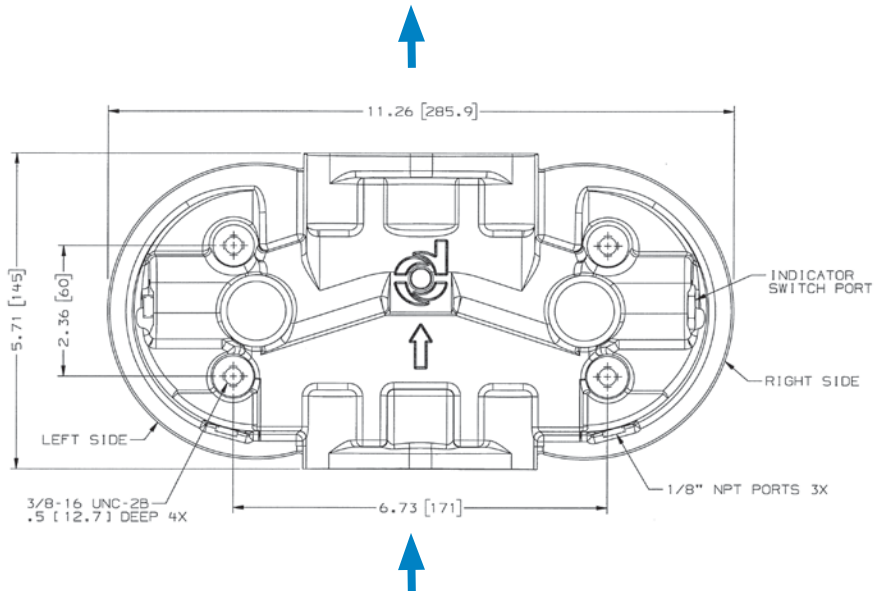



SP80/90

Max Flow: 100 gpm (379 lpm)



SP80/90 Components

Filter Choices

Media Type	$\alpha_{x(e)} = 1000$	$\beta_{x(e)} = 2$	$\beta_{x(e)} = 1000$	Length		Part No.	Comments
	Rating based on ISO 23369	Rating based on ISO 16889		in	mm		
Synteq Synthetic			<4 μm	10.7	271	P167796	Fluorocarbon O-Ring & square seal kit. Compatible w/ water glycol.
			6 μm	6.7	170	P167162	3-seal kit
			6 μm	10.7	271	P165762	3-seal kit
Alpha-Web	10 μm			6.7	170	DBH5875	3-seal kit
Synteq Synthetic			11 μm	6.7	170	P165875	3-seal kit
			11 μm	10.7	271	P165876	3-seal kit
			13 μm	6.7	170	P167944	Fluorocarbon O-Ring & square seal kit. Compatible w/ water glycol.
			13 μm	10.7	271	P167945	Fluorocarbon O-Ring & square seal kit. Compatible w/ water glycol.
			23 μm	6.7	170	P165877	3-seal kit
			23 μm	10.7	271	P165878	3-seal kit
			50 μm	6.7	170	P165879	3-seal kit
			50 μm	10.7	271	P165880	3-seal kit
Cellulose		5 μm		6.7	170	P550386	3-seal kit
		5 μm		10.7	271	P550250	3-seal kit
		7 μm		7.2	183	P550388	3-seal kit
		7 μm		10.7	271	P550251	3-seal kit
		7 μm		7.00	178	P565245	Square seal kit, 1/4" BSP thread
		17 μm		6.7	170	P550387	3-seal kit
		17 μm		10.7	271	P550252	3-seal kit
		27 μm		7.00	178	P171616	Square seal kit, 1/4" BSP thread
Water Absorbing		10 μm		10.7	271	P561183	Cellulose media, 3-seal kit. Absorbs 350 ml water.
Wire Mesh		150 μm		6.7	170	P550275	Stainless steel wire mesh, 3-seal kit
		150 μm		10.7	271	P550276	Stainless steel wire mesh, 3-seal kit

All models have 1 1/2-16 UNF threads except where otherwise noted. All models measure 5.07/127mm outer diameter.

Head Choices

Port Size	Bypass Rating	Gauge Ports (drill, tap, plug)	Gauge Port Location	Part No.
1 1/2" NPT & 2" SAE 4 Bolt	15 psi / 103.4 kPa / 1.34 bar	(4) 1/8" NPT	upstream & downstream sides	P563273
1 1/2" NPT & 2" SAE 4 Bolt	25 psi / 172.5 kPa / 1.72 bar	(4) 1/8" NPT	upstream & downstream sides	P563274
1 1/2" NPT & 2" SAE 4 Bolt	No Bypass	(4) 1/8" NPT	upstream & downstream sides	P563275
1 1/2" NPT & 2" SAE 4 Bolt	5 psi / 34.5 kPa / .34 bar	(4) 1/8" NPT	upstream & downstream sides	P563276
SAE-24 O-Ring	25 psi / 172.5 kPa / 1.72 bar	(4) 1/8" NPT	upstream & downstream sides	P564892
SAE-24 O-Ring	No Bypass	(4) 1/8" NPT	upstream & downstream sides	P573217

Note: On a return line system the gauge port should be on the upstream side. We suggest a 25 psi bypass. If head is used on a suction line, the gauge port should be on the downstream side very low bypass.

Gaskets

Each filter ships with a 3-seal kit, containing an "L" shaped, a square cut, and an O-Ring gasket seal, unless otherwise noted. Use only one of the following seals. Installation instructions can be found in the technical reference section.

- L Shaped
Use with filter heads with no groove or a wide groove.
- Square Cut
Use with filter heads with a narrow groove.
- O-Ring -246
Use with Donaldson HBK05 heads only.

Optional Filter Service Indicators for Left Side

Part No.	Pressure Range	Use With Bypass Valve Rating	Type
P563978	5 to 30 psi field adj.*	15 psi / 103.4 kPa / 1.34 bar or 25 psi / 172.5 kPa / 1.72 bar or No Bypass	Return indicator, electrical
P579714	0 to 100 psi	15 psi / 103.4 kPa / 1.34 bar or 25 psi / 172.5 kPa / 1.72 bar or No Bypass	Return indicator, numeric scale
P579715	0 to 100 psi	15 psi / 103.4 kPa / 1.34 bar Bypass	Return indicator, color coded
P579716	0 to 100 psi	25 psi / 172.5 kPa / 1.72 bar or No Bypass	Return indicator, color-coded
P579717	0 to -30 Hg	5 psi / 34.5 kPa / .34 bar or No Bypass	Suction indicator, numeric scale

P563978

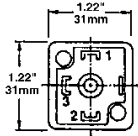

#1 Common; #2 Normally Closed;
#3 Normally Open

Instructions

1. Remove DIN adaptor
2. Remove small brass screw
3. Using 1/8" allen wrench adjust clockwise to increase set point/counter-clockwise to decrease set point
4. NO / NC

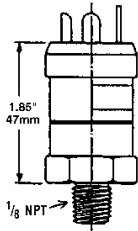

Adjustment screw located in center of electric prongs

P579714 - P579717

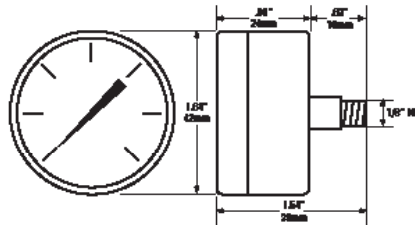

Notes

* NOT PRESET: Setting adjustable for desired application

Optional Filter Service Indicators for Right Side

Refer to Filter Service Indicators pages of the accessories section for right side electrical filter service indicator options.

Performance Data

