

RF Baghouse Dust Collector

RFT, RFW, and RFWH (All Welded or Knock Down)

Installation and Operation Manual

Installation, Operation, and Service Information

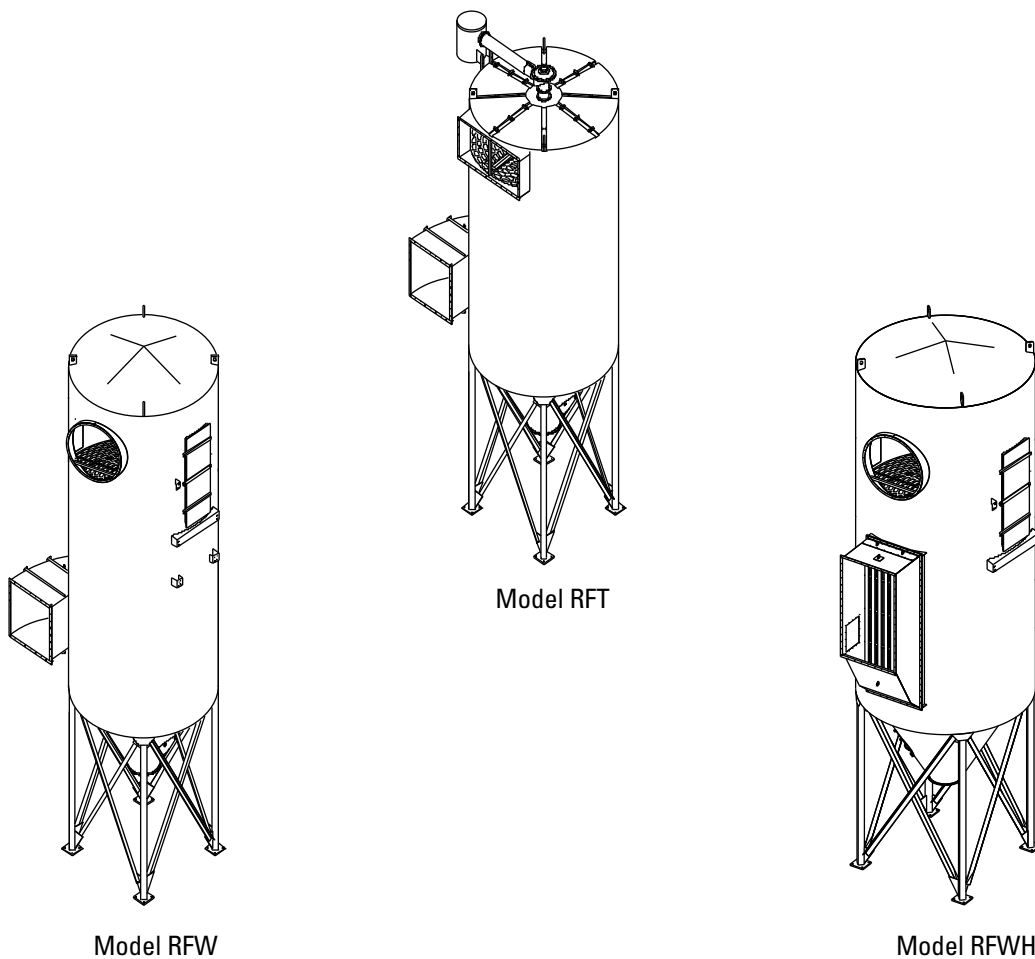

This manual contains specific precautions related to worker safety. The hazard alert image denotes safety related instructions and warnings in this manual. DO NOT install, operate, or perform maintenance on this collector until you have read and understood the instructions, precautions and warnings contained within this manual.

IMPORTANT NOTES

This manual has been supplied to assist with the installation, operation and maintenance for the collector purchased. Please read the manual before installing, operating, or performing maintenance on the collector as it contains specific precautions for worker safety. It is the owner's responsibility to ensure that this manual is available for use by installers, operators and maintenance personnel that will be working with this collector. This manual is the property of the owner and should be left with the collector when installation has been completed. **DO NOT** operate this collector until you have read and understood the instructions and warnings located in the installation and operation manual.

For additional copies of this manual, contact Donaldson Torit.



The Safety Alert Symbol indicates a hazardous situation which, if not avoided could result in death or serious injury. Obey all safety messages following this symbol to avoid possible injury or death. The possible hazards are explained in the associated text messages.

 **CAUTION**

CAUTION, used with the safety alert symbol, indicates a hazardous situation which, if not avoided, could result in minor or moderate injury.

NOTICE

NOTICE indicates a potential situation or practice which is not expected to result in personal injury, but which if not avoided, may result in damage to equipment.

Contents

IMPORTANT NOTES	2
Safety Communication	4
Description	6
Purpose and Intended Use	7
Rating and Specification Information	7
Involute Scroll Inlet Operation	8
High Inlet Operation	8
Inspection on Arrival	9
Installation Codes and Procedures	9
Installation	9
Standard Equipment	11
Leg Installation	11
Section Assembly	12
Inlet Scroll Installation	13
High Inlet Installation	14
Ladder/Platform Installation	14
Electrical Wiring	16
Cleaning Mechanism Assembly and Adjustment	16
Solid-State Timer Installation	19
Felt Bag and Cage with Boltsafe™ Hardware Filter Installation	22
Pleated Bag with Boltsafe™ Hardware Filter Installation	22
Pleated Bag with Snap-In Design Filter Installation	23
Felt Snap-In Bag Filter Installation	24
Preliminary Start-Up Check	26
Maintenance Information	29
Inlet Baffle Assembly Replacement	30
Filter Removal and Installation	30
Felt Bag and Cage with Boltsafe™ Hardware Filter Installation	31
Optional Equipment	36
Plant Air Kit	36
Magnehelic® Gauge	37
Photohelic® Gauge	38
Explosion Vent	40
Troubleshooting	41
Product Information	44
Service Notes	45
Donaldson Industrial Air Filtration Warranty	47

Safety Communication



Improper operation of dust collectors and/or dust control systems may contribute to conditions in a work area or facility which could result in severe personal injury, and product or property damage. All dust collection equipment should be used only for its intended purpose and should be properly selected and sized for its intended use.

Process owners have important responsibilities relating to identifying and addressing potential hazards in their processes. When the potential for handling combustible dust exists within a process the process owner should include combustion hazards in their risk management activities and should comply with applicable codes and standards related to combustible dust.

Electrical installation must be performed by a qualified electrician.

This equipment is not designed to support site ducts, piping, or electrical services. All ducts, piping, or electrical services must be adequately supported to prevent injury and/or property damage.

Site selection must account for wind, seismic zone, and other load conditions.

Equipment may reach peak sound pressure levels above 80 dB (A). Noise levels should be considered when selecting collector location.

Most dusts present safety and health hazards that require precautions. Wear eye, respiratory, head and other protection equipment suitable for the type of dust.

Some components may be heavier than they appear. Use appropriate lifting methods to avoid personal injury and/or property damage.

Combustible Dust Hazards

Among other considerations, the current NFPA standards require owners whose processes involve potentially combustible materials to have a current Dust Hazard Analysis, which can serve as the foundation for their process hazard mitigation strategy. Mitigation may include but is not limited to:

- Prevention of all ignition sources from entering any dust collection equipment.
- Selection and implementation of fire and explosion mitigation, suppression, and isolation strategies appropriate for the risks in their process.
- Development and use of work practices to maintain safe operating conditions, and to ensure combustible dust does not accumulate within their plant or process equipment.

Donaldson designs, manufactures, and sells industrial air filtration products for a wide variety of applications. Some applications may include processes or materials with inherent fire and explosion hazards. Donaldson is neither an expert nor a certified consultant in fire, spark, or explosion detection, suppression, or control. Donaldson does not provide engineering consulting services related to process or dust hazard analyses, or code and standard compliance. Complying with applicable codes and standards and managing the risks associated with the process or materials remains the responsibility of the process owner/operator. Donaldson may provide referrals to consultants, suppliers of equipment or services related to the detection and/or mitigation of sparks, fires and/or explosions, but Donaldson does not assume responsibility for any such referrals, nor does Donaldson assume any liability for the fitness of a mitigation strategy or product for a particular installation or application. The process owner's final selection of dust collectors and risk mitigation strategies should be based on the outcome of a Dust Hazard / Process Hazard Analysis performed by the process owner. Although early engagement of a dust collector supplier provides helpful insights on the availability and features of various products, process owners should consult with a combustible dust expert and/or a process safety expert before making actual product and mitigation strategy selections.

Donaldson recommends that all industrial air filtration system designs be reviewed and approved by an expert consultant who is responsible for the integrity of the system design and compliance with applicable codes and standards. It is the process owner's responsibility to understand the risks in their process and mitigate those risks in accordance with all applicable laws, regulations and standards, including those published by the NFPA. Donaldson also recommends that proper maintenance and housekeeping procedures and work practices be evaluated, developed, and followed to maintain any industrial air filtration products in safe operating condition.

Many factors beyond the control of Donaldson can affect the use and performance of Donaldson products in a particular application, including the conditions under which the product is used. Since these factors are uniquely within the user's knowledge and control, it is essential the user evaluate the Donaldson products to determine whether the product is fit for the particular purpose and suitable for the user's application. All products, product specifications, and data (airflow, capacity, dimensions, or availability) are subject to change without notice, and may vary by region or country.

Description

The RF Baghouse is a continuous duty dust collector with bag-style filters designed to handle applications with heavy dust loads. Continuous-duty means the filters can be pulse cleaned on-line without interrupting airflow through the collector. A timer energizes the cleaning system to ensure the bag-style filters are cleaned at least once every four minutes.

The cylindrical collectors housing design features an all-welded or an optional bolt-together construction in standard sizes from 48 to 484 filter bags with either 8, 10, or 12-ft long bag-style filters. The collector housing design can include an involute scroll inlet or an upper body radial high inlet.

The involute inlets are typically used for heavy non-abrasive dust loading applications. These inlet styles allow the majority of the incoming dust to cyclonically separate. The heavier dust separated in these inlets is directed downward into the hopper while the lighter dust is passed through air straightening veins to evenly distribute the air and entrained dusts over the filter bags for final separation.

The upper body radial style high inlet is typically used on lower density dust type applications. This style of inlet is located in the filter housing section below the tubesheet, and directs the incoming dust particles downward around the filter bags and into the hopper. This flow path assists the cleaning system by supporting an airflow pattern that encourages the dislodged dust pulsed off the filter bags to move downward into the hopper. Baffles in the inlet keep dusts from directly impinging on the filter tubes.

The RF Baghouse is available in two different access styles. RFT models which allow walk-on, top-access bag removal, and RFW / RFWH models which feature a walk-in clean-air plenum. All models allow filter-bag service from the clean-air side of the collector.

Purpose and Intended Use



Misuse or modification may result in severe personal injury and/or property damage.

Do not misuse or modify.

The RF Baghouse collector is common in the woodworking and grain industries where it effectively handles high-volume, high dust-load applications. Additional applications include cement, chemical, and food processing applications especially sugar and other moisture-sensitive materials.

- The RF is typically used in applications over 25,000 cfm.
- Sizes are available for lower airflow applications with any of the following conditions or requirements:
- Heavy dust load
- No compressed air available
- A round collector required for sanitary reasons
- High pressure or vacuum requirement
- A requirement for a single discharge hopper.

Operations involving higher temperatures, humidity, or air stream chemistry may require customized collector design options. Contact Donaldson Torit for design assistance.

Rating and Specification Information

General rating and specification information can be found in the product literature provided with the collector or available on the Donaldson website. For specific load values for a collector, see the Specification Control Drawing shipped with the collector.

Involute Scroll Inlet Operation

During normal operation of a RF with an involute scroll inlet, dust-laden air enters the dirty-air inlet. The involute scroll inlet creates a cyclonic action and a baffle just above the inlet prevents the incoming dust from directly contacting the filter bags. The cyclonic action and baffle forces the heavier dust particles to fall directly into the hopper. The lighter dust particles will then pass through air straightening veins that evenly distribute the air and entrained dust into the filter bag section.

After entering the collector, the light dust collects on the outside surface of each filter bag forming a dust cake. Clean, filtered air passes through the filter bags, into the clean-air plenum, and discharges through the clean-air outlet.

The RF cleaning system automatically cleans each bag at least once every four minutes. During the filter cleaning cycle, a solid-state timer energizes a solenoid valve and controls the open and close time of the

diaphragm valve. An air reservoir stores pressurized air which the diaphragm valve directs through the manifold arms and into the filter bags forcing the collected dust to fall into the hopper where it is discharged into drums, rotary valve, screw conveyor, or pneumatic conveying system.

High Inlet Operation

During normal operation of a RF with a high inlet, dust-laden air enters the bag section of the collector. The high inlet section contains baffles that prevent direct impingement of the incoming dust on the filter bags, forcing the dust to slow down and change direction before entering the filter bag section. The incoming dust laden air travels downward into the hopper. This downward flow path assists the cleaning system to force dislodged dust into the hopper preventing re-entrainment of the dust on adjacent filter bags.

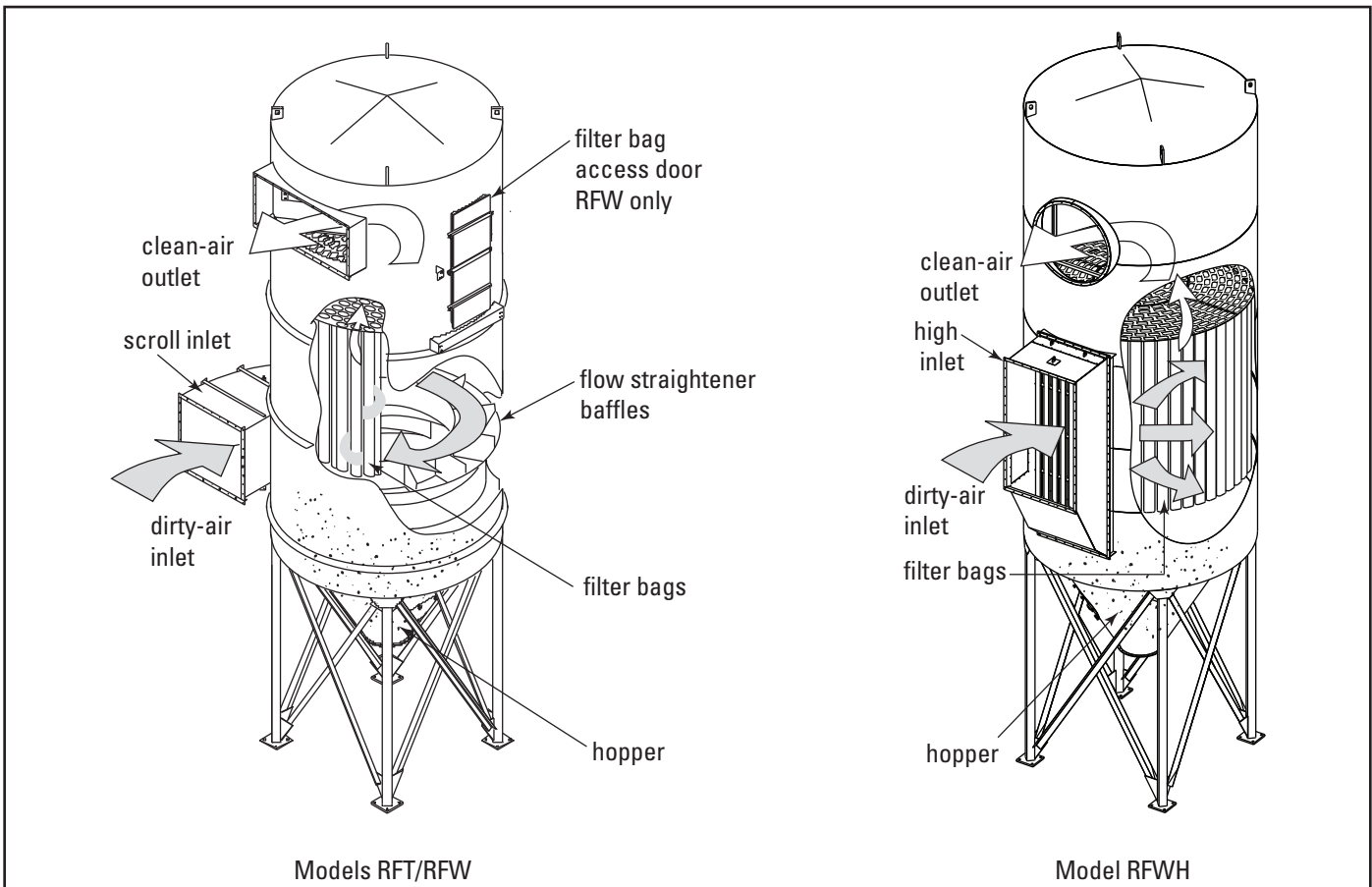

Collector Operation

Inspection on Arrival

1. Inspect collector upon delivery.
2. Report any damage to the delivery carrier.
3. Request a written inspection report from the Claims Inspector to substantiate any damage claim.
4. File claims with the delivery carrier.
5. Compare collector received with description of product ordered.
6. Report incomplete shipments to the delivery carrier and your Donaldson Torit representative.
7. Remove crates and shipping straps. Remove loose components and accessory packages before lifting collector from truck.
8. Check for hardware that may have loosened during shipping.
9. Use caution removing temporary covers.

Installation Codes and Procedures



Codes may regulate recirculating filtered air in your facility. Consult with the appropriate authorities having jurisdiction to ensure compliance with all national and local codes regarding recirculating filtered air.

Safe and efficient operation of the collector depends on proper installation.

Authorities with jurisdiction should be consulted before installing to verify local codes and installation procedures. In the absence of such codes, install collector according to the National Electric Code, NFPA No. 70-latest edition and NFPA 91 (NFPA 654 if combustible dust is present).

A qualified installation and service agent must complete installation and service of this equipment.

All shipping materials, including shipping covers, must be removed from the collector prior to or during collector installation.

NOTICE

Failure to remove shipping materials from the collector will compromise collector performance.

Inspect collector to ensure all hardware is properly installed and tight prior to operating collector.

Installation



Use proper equipment and adopt all safety precautions needed for servicing equipment.

Electrical service or maintenance work must be performed by a qualified electrician and comply with all applicable national and local codes.

Turn power off and lock out all power before performing service or maintenance work.

Do not install in classified hazardous atmospheres without an enclosure rated for the application.

Site selection must account for wind, seismic zone, and other load conditions when selecting the location for collectors.

Codes may regulate acceptable locations for installing dust collectors. Consult with the appropriate authorities having jurisdiction to ensure compliance with all national and local codes regarding mist collector installation.

Collectors must be anchored in a manner consistent with local code requirements. Anchors must be sufficient to support dead, live, seismic, and other anticipated loads.

Consult a qualified engineer for final selection of anchorage.

The collector is suitable for either indoor or outdoor installations. Reference the Rating and Specification Information.

Foundations or Support Framing

Prepare the foundation or support framing in the selected location. Foundation or support framing must comply with local code requirements and may require engineering.

Foundation and support framing must be capable of supporting dead, live, wind, seismic and other applicable loads. Consult a qualified engineer for final selection of foundation or support framing.

Collector Location



Donaldson Torit equipment is not designed to support site installed ducts, interconnecting piping, or electrical services. All ducts, piping, or electrical services must be adequately supported to prevent severe personal injury and/or property damage.

When hazardous conditions or materials are present, consult with local authorities for the proper location of the collector.

Dust collection equipment may reach peak sound pressure levels above 80 dB (A). Noise levels should be considered when selecting collector location.

Locate the collector to ensure easy access to electrical and compressed air connections, to simplify solids collection container handling and routine maintenance, and to ensure the straightest inlet and outlet ducts.

Provide clearance from heat sources and avoid any interference with utilities when selecting the location.

Ensure the inlet has at least five diameters of straight duct prior to the collector inlet including a transition to the full inlet dimensions. Inlet transition should have a taper with a maximum of a 90-degree included angle.

Consider the effects of condensation caused by temperature difference between the process airstream and outdoor temperatures.

Consider forklift access for solid collection container removal.

Site Selection

This collector can be located on a foundation or structural framing.

Lifting Information



Failure to lift the collector correctly can result in severe personal injury and/or property damage.

Use appropriate lifting equipment and adopt all safety precautions needed for moving and handling the equipment.

A crane or forklift and qualified operator are recommended for unloading, assembly, and installation of the collector.

Location must be clear of all obstructions, such as utility lines or roof overhang.

Use all lifting points provided.

Use clevis connectors, not hooks, on lifting slings.

Use spreader bars to prevent damage to collector's casing.

Check the Specification Control drawing for weight and dimensions of the collector and components to ensure adequate crane capacity.

Allow only qualified crane or forklift operators to lift the equipment.

Refer to applicable OSHA regulations and local codes when using cranes, forklifts, and other lifting equipment.

Lift collector and accessories separately and assemble after collector is in place.

Use drift pins to align holes in section flanges during assembly.

Standard Equipment

After removing any accessory equipment that may have been stored inside collector, all welded collectors can be lifted from the truck to the prepared site. Bolt-together collectors are assembled at the site.

Note: If installing an all-welded collector, skip to Inlet Scroll Installation.

Leg Installation

CAUTION

Anchors must comply with local code requirements and must be capable of supporting dead, live, wind, seismic, and other applicable loads.

Anchor sizes shown are provisional, as final anchor sizing will depend on jobsite load conditions, collector location, foundation/framing design variables and local codes.

Consult a qualified engineer for final selection of suitable anchors.

NOTICE

Temporary support is required until all legs and cross-bracing are in place.

Reference Typical Foundation Anchor and leg assembly drawing shipped with the collector prior to starting assembly.

1. Prepare the foundation or support framing in the selected location. Locate and install anchors.
2. Place the hopper upside down on a flat secure surface.
3. Attach legs to hopper gussets using the hardware supplied. Assemble cross braces as shown in Leg and Cross Brace Assembly. Do not tighten hardware at this time.
4. Turn leg and hopper assembly over and position over anchor bolts. Secure each leg pad to the foundation anchor bolts with customer-supplied flat washers, lock washers, and nuts. Do not tighten hardware at this time.
5. Level hopper.
6. Tighten all hardware securing legs, cross braces, hopper gussets, and foundation anchor bolts.

CAUTION

Tighten all hardware before removing crane to prevent personal injury and/or property damage.

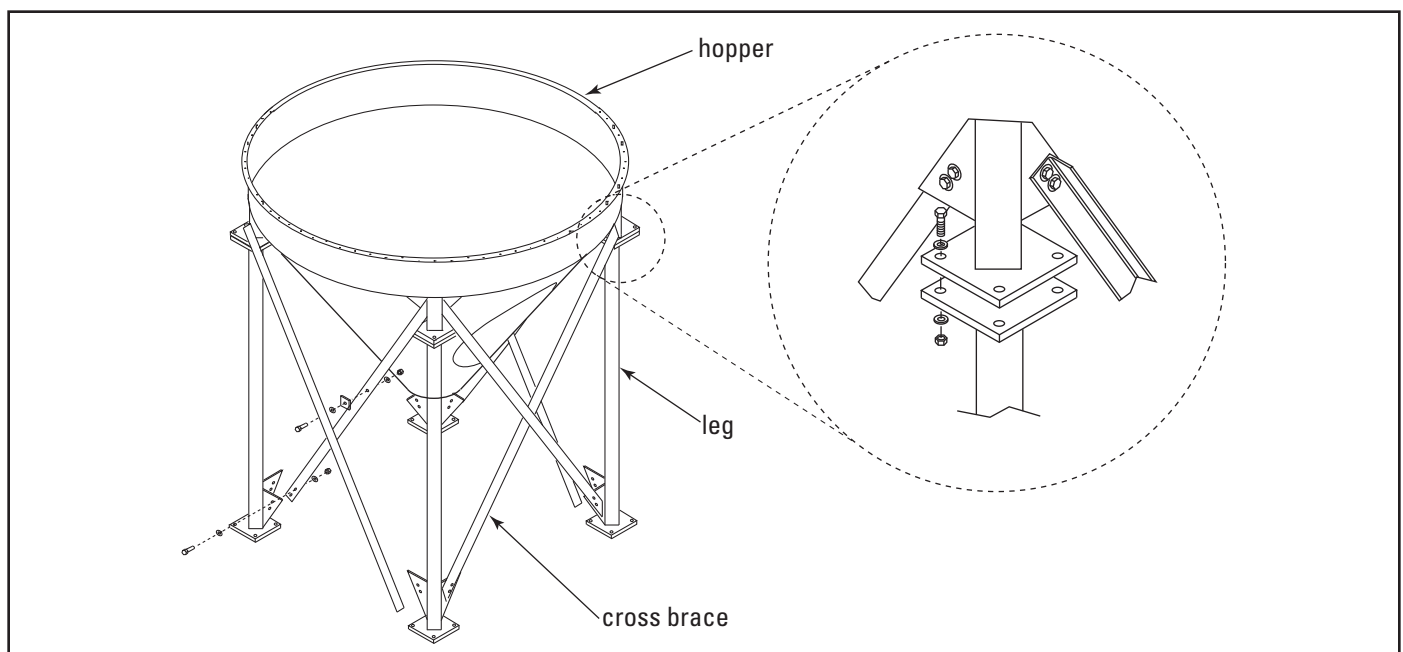

Leg and Cross Brace Assembly (Knock-Down Version Shown)

Provisional Anchor Bolt Recommendations

1. Consider Hilti HIT-HY 200 Anchor System or equivalent. Quantity of anchor bolts should match the number of holes provided in the base plates.
2. Anchor diameter is typically 1/8 to 1/2-in less than baseplate hole diameter.
3. Corrosive environment or outdoor installation may require stainless steel anchors.

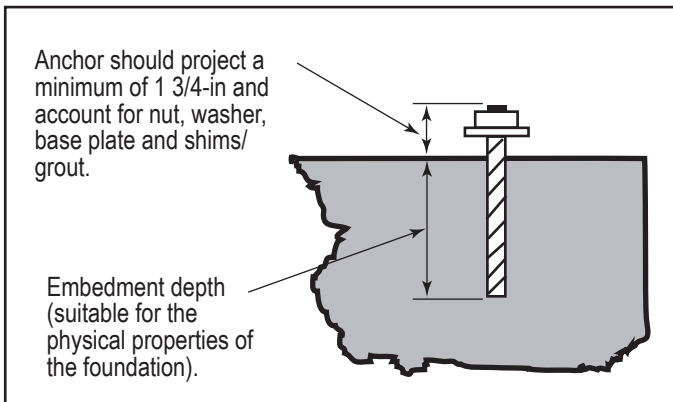

Typical Foundation Anchor

Section Assembly

1. Reference the Specification Control Drawing for inlet and outlet orientation.
2. Apply 1/4-in diameter, rope-type sealant to the hopper's top flange.
3. Lift the inlet section into position over the hopper and lower slowly. Temporary eye bolts (not provided) may be used for lifting. Ensure enough bolts are used for stability depending on grade of bolt and angle of lift.
4. Use drift pins to align holes in the section flanges and secure using the hardware provided.
5. Repeat Steps 2 through 4 to install the filter section and clean-air plenum.

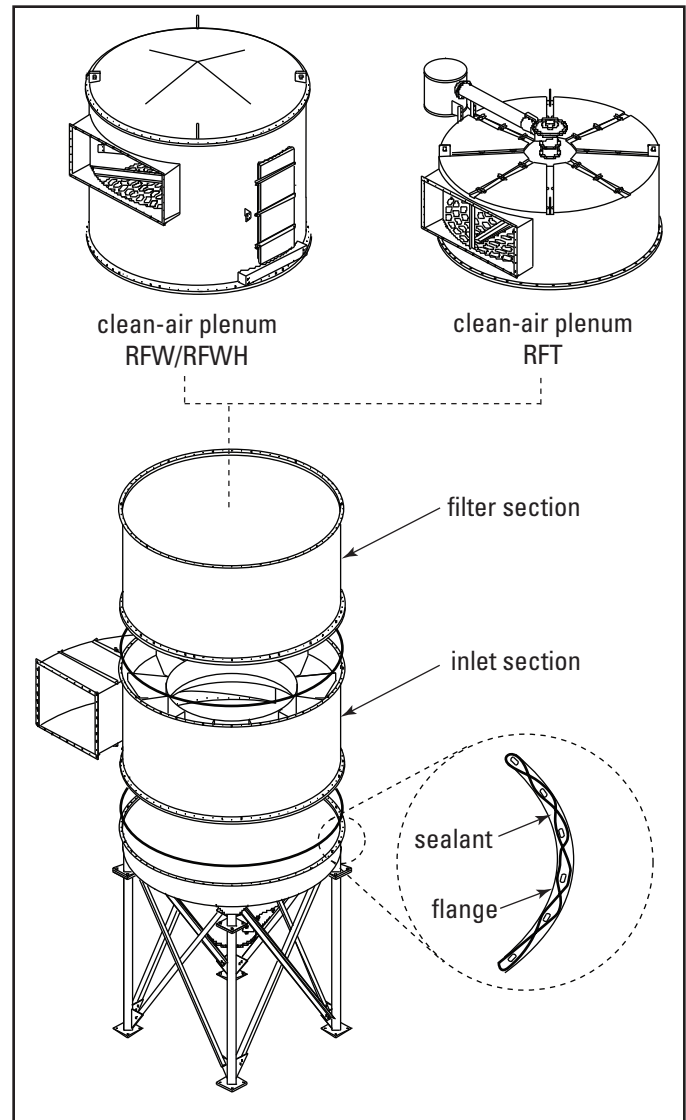

Section Assembly (Knock-Down Version Shown)

Inlet Scroll Installation

1. After the collector housing is upright and secure, remove the temporary vertical supports from the inlet scroll opening on the collector.
2. Place 1/4-in diameter, rope-type sealant toward the inside and outside edge of the bolt pattern in a figure 8 pattern such that sealant will be on inside and outside edge of all flange bolt holes on the inlet-section scroll mounting flanges.
3. Lift inlet scroll into position and secure with the hardware provided.

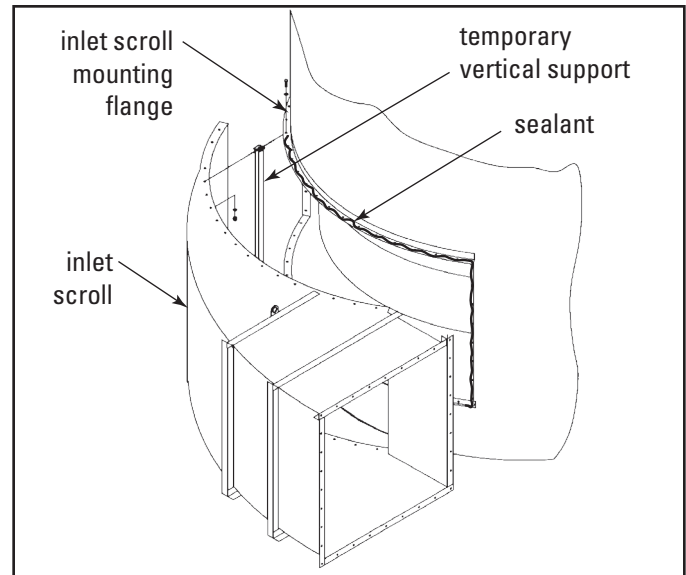

Inlet Scroll Installation
(Clockwise inlet shown)

High Inlet Installation

1. After the collector housing is upright and secure, remove the braces from the high inlet opening on the collector.
2. Place 1/4-in diameter, rope-type sealant toward the inside and outside edge of the bolt pattern in a figure 8 pattern on the inlet section mounting flanges.
3. Lift high inlet into position and secure with the hardware provided.

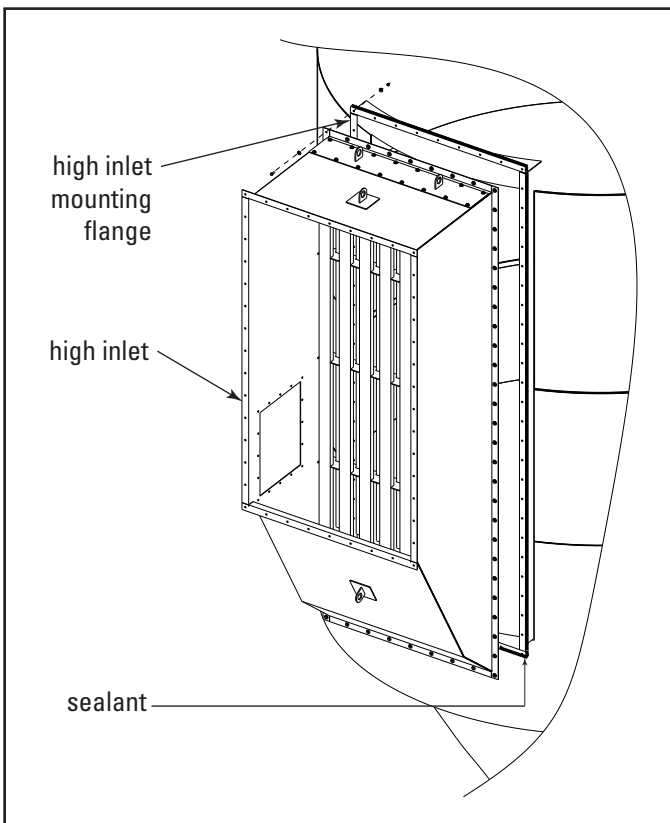

High Inlet Installation

Ladder/Platform Installation

1. Attach the knee braces to the platform assembly shown on drawings shipped with collector.
2. Lift the platform assembly into position.
3. Remove the hardware located where the platform assembly and knee braces will connect to the body panel flanges.
4. Position the platform assembly, then reinstall and tighten the existing hardware including the bolted connections for the platform railing and knee braces.
5. Assemble the entire ladder sub-assembly per the drawing provided. Temporarily bolt the adjustable, bottom angle anchors at the highest position.
6. If applicable, install the lower intermediate ladder support to the leg pack following the drawing provided.
7. Lift the completed ladder assembly into position and fasten to the platform assembly.
8. Install the remaining intermediate support. Match drill the ladder assembly per the drawing provided and attach to the support.
9. If applicable, match drill the ladder assembly and attach to the lower intermediate support.
10. Loosen the bottom ladder section and position it to touch the collector foundation. Concrete anchors will be required to complete this connection.

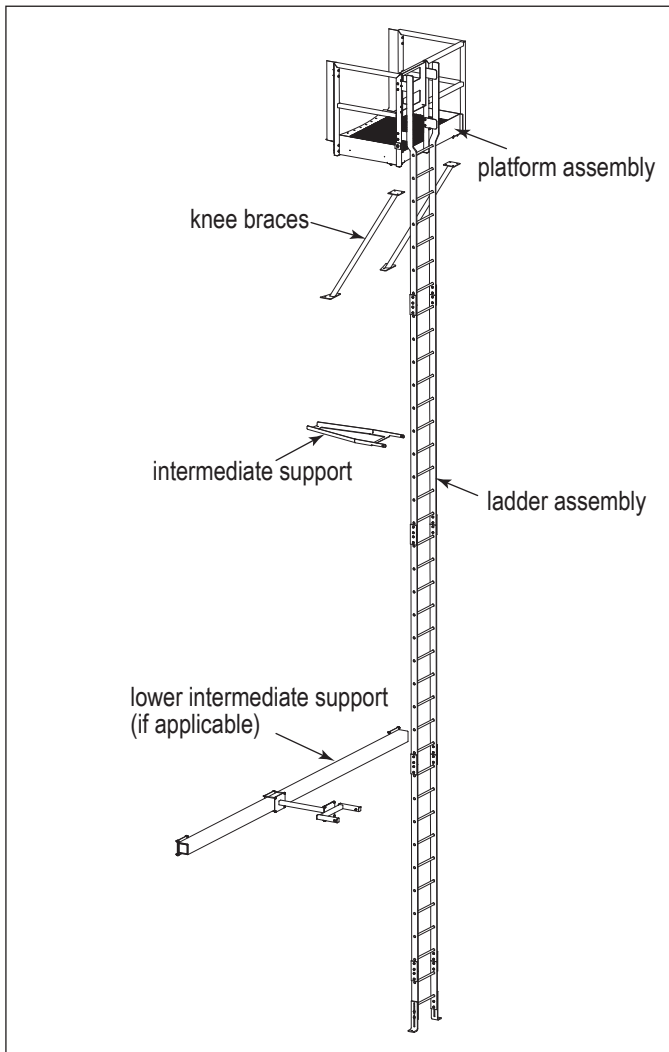

Platform Installation

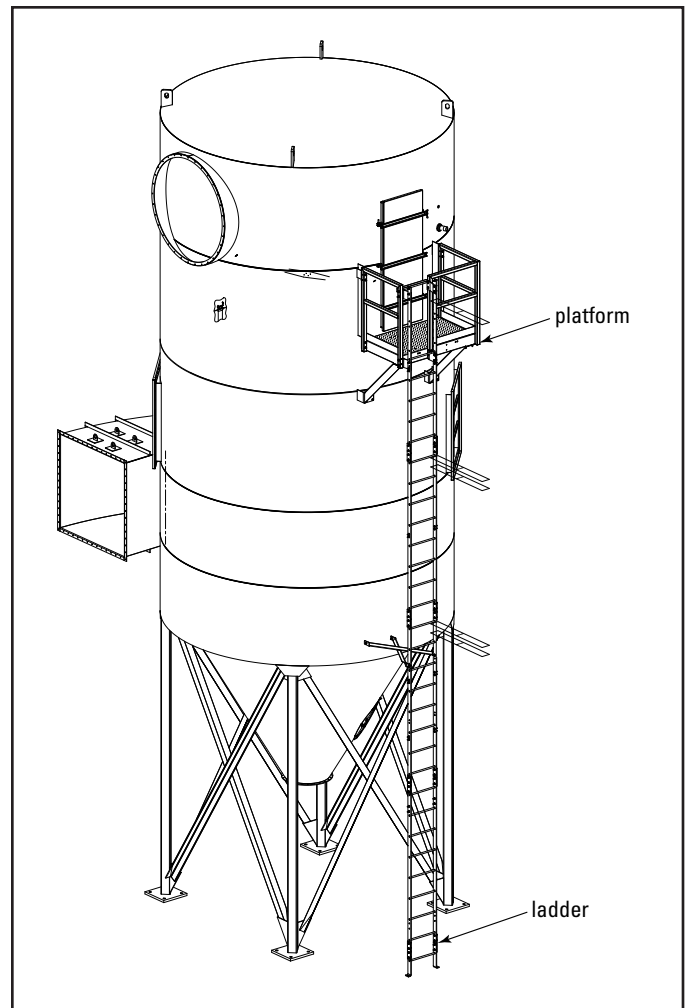

Ladder Installation

Electrical Wiring

CAUTION

Electrical installation, service, or maintenance work must be performed by a qualified electrician and comply with all applicable national and local codes.

Turn power off and lock out all power before performing service or maintenance work.

Do not install in classified hazardous atmospheres without an enclosure rated for the application.

All electrical wiring and connections, including electrical grounding, should be made in accordance with the National Electric Code (NFPA No. 70-latest edition).

Check local ordinances for additional requirements that apply.

The appropriate wiring schematic and electrical rating must be used. See collector's rating plate for required voltage.

An electric disconnect switch having adequate amp capacity shall be installed in accordance with Part IX, Article 430 of the National Electrical Code (NFPA No. 70-latest edition). Check collector's rating plate for voltage and amperage ratings.

Refer to the wiring diagram for the number of wires required for main power wiring and remote wiring.

Cleaning Mechanism Assembly and Adjustment

CAUTION

Electrical installation, service, or maintenance work must be performed by a qualified electrician and comply with all applicable national and local codes.

Turn power off and lock out all power before performing service or maintenance work.

Do not install in classified hazardous atmospheres without an enclosure rated for the application.

If the collector was supplied with an electrical control panel, the wiring diagram supplied with the control panel takes precedence over the general diagrams shown in this manual.

1. The gear reducer ships prefilled with lubricant. Remove the pipe plug and install the breather.
2. Remove the plastic exhaust-port plug from the bottom of the solenoid valve.
3. Wire the motor to a customer-supplied motor starter with overload and short circuit protection.
4. Remove all shipping restraints from manifold arms and shipping braces from the cleaning system and cleaning system support frame.

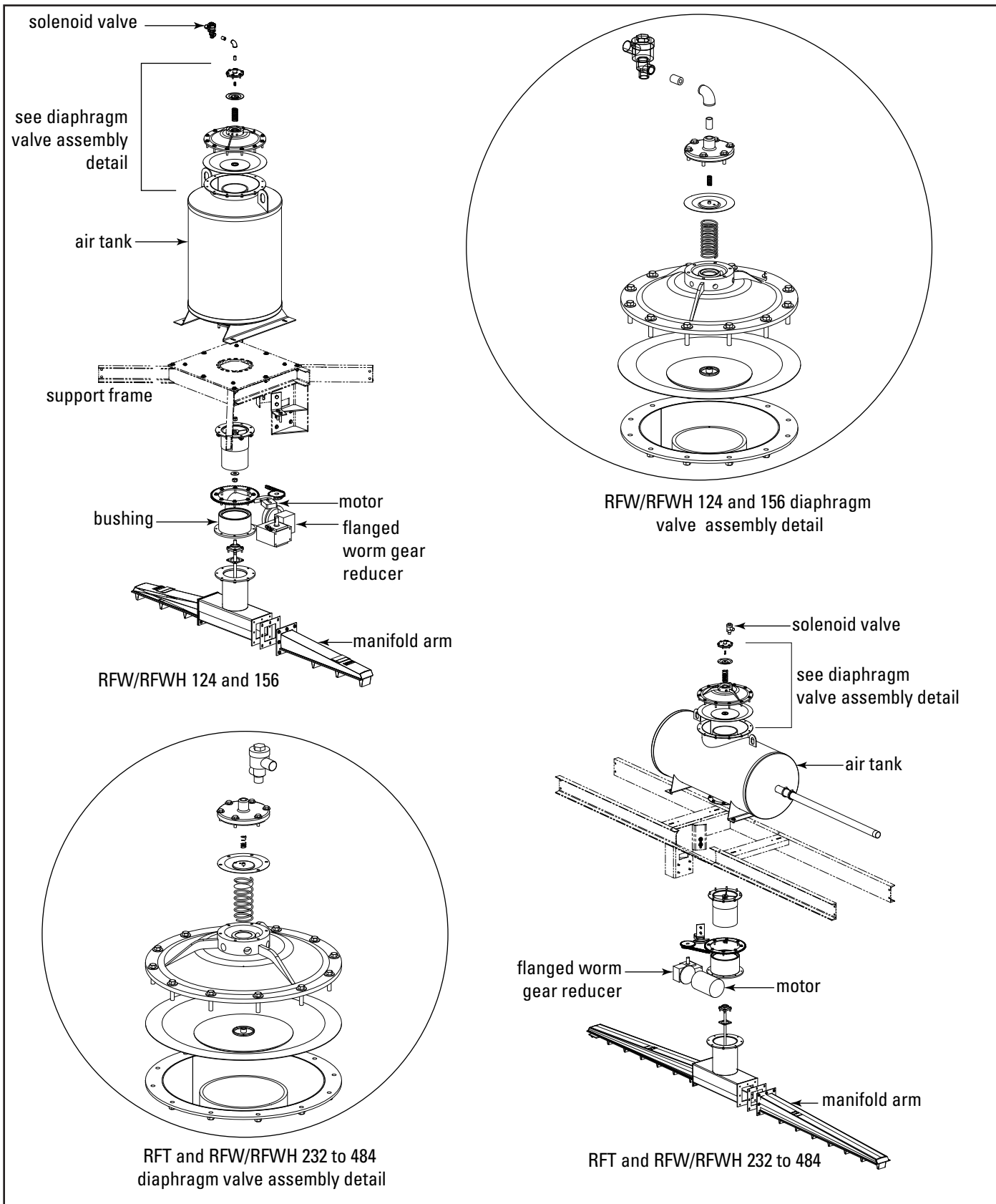

Cleaning Mechanism

Air Supply

A positive-displacement blower provides the pressurized air required for filter cleaning. The blower is sized for each collector based on the model and airflow requirements. Follow the installation instructions provided with the positive-displacement blower.

Air Supply Pipe Sizing	
Model	Pipe Diameter
48-72	1-in
124-156	1 1/4-in
232-276	1 1/2-in
376 and 484	2-in

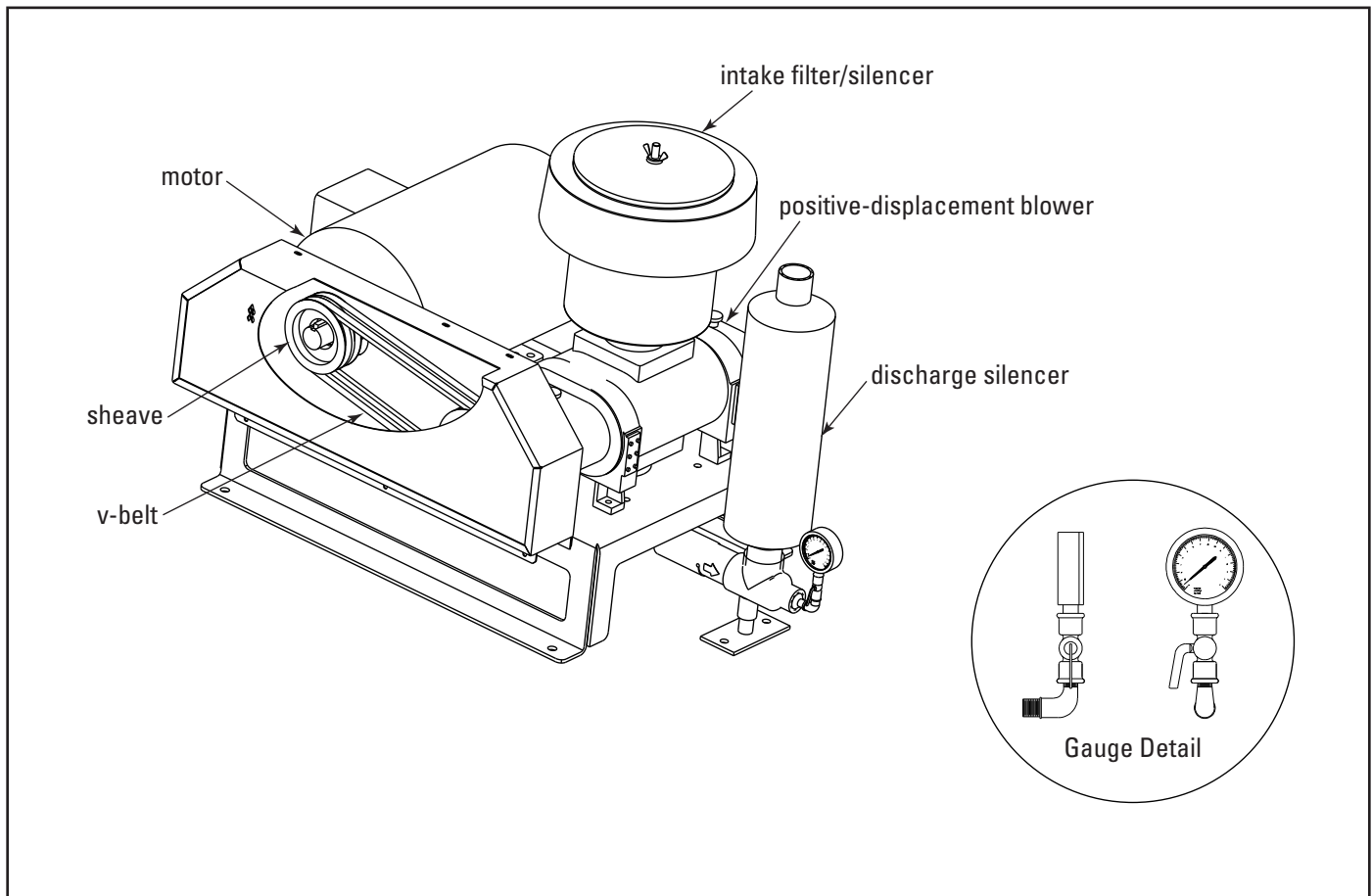

Positive-Displacement Blower Assembly

Solid-State Timer Installation

CAUTION

Electrical installation, service or maintenance work during installation must be performed by a qualified electrician and comply with all applicable national and local codes.

Turn power off and lock out all power before performing installation, service, or maintenance work.

Do not install in classified hazardous atmospheres without an enclosure rated for the application.

The solid-state timer is used to control the filter cleaning system.

1. Choose a location convenient for accessibility and maintenance.
2. Using the wiring diagram supplied, wire the blower motor, blower-motor starter, solid-state timer, and solenoid valve. Use appropriate wire gauge for rated amp load as specified by the local codes.

NOTICE

The solid-state timer requires a 105 to 135-Volt, customer-supplied power supply.

Do not mount the solid-state timer directly to the collector or the positive displacement blower as mechanical vibration can damage the timer.

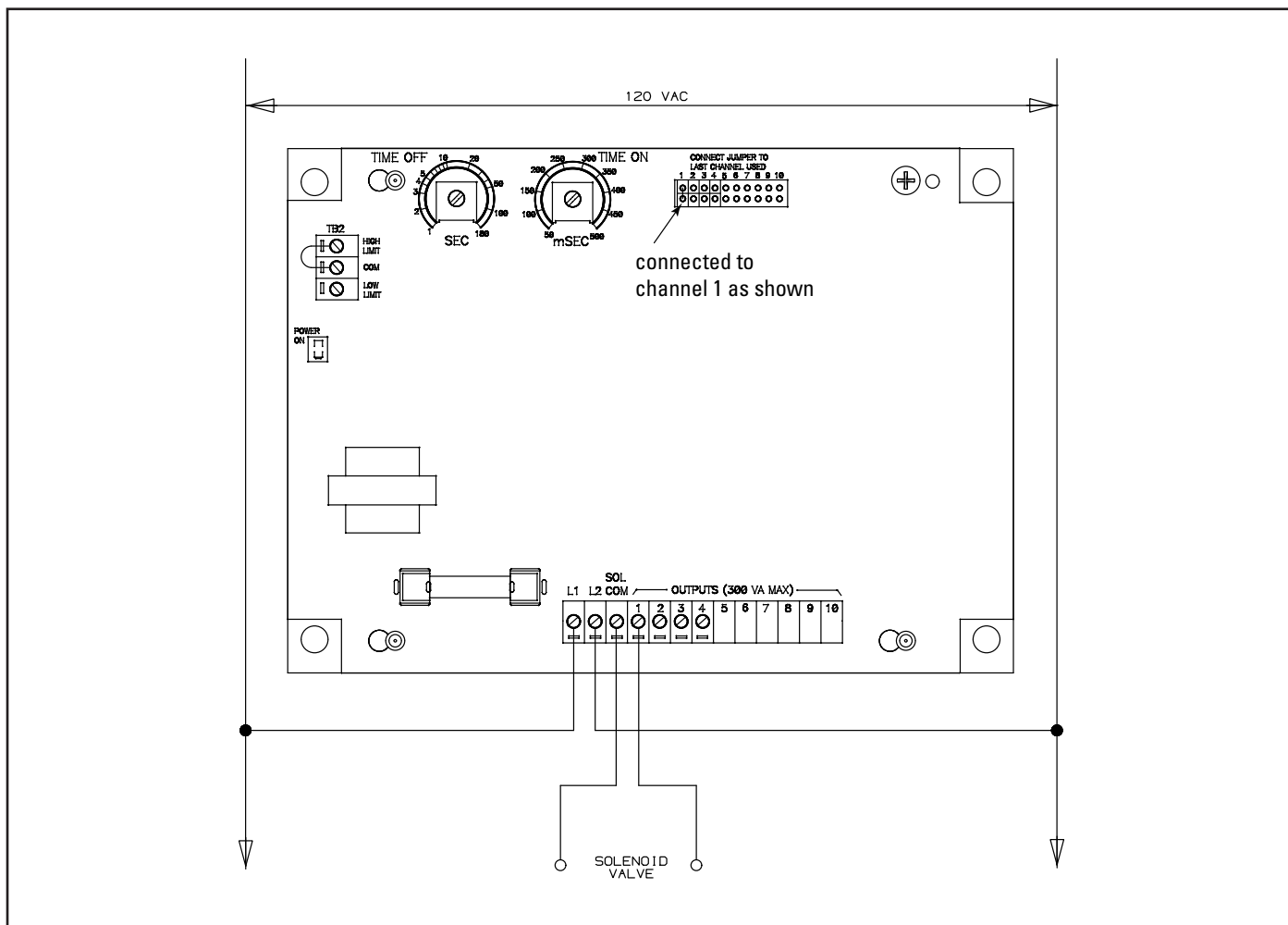

Timer Wiring

Solenoid Connection

The collector is equipped with a solenoid valve (typically 120V) that controls the pulse-cleaning valve, which cleans the filters.

Wire the solenoids to the solid-state timer following the wiring diagram supplied with the collector. Filter life and cleaning operation will be affected if not wired correctly.

Timer and Solenoid Specifications

Power to the solid-state timer is supplied to Terminals L1 and L2, which are intended to operate in parallel with the positive displacement blower starter's low-voltage coil. On fan start-up, power is supplied to the timer and the preset OFF time is initiated. At the end of the OFF time, the timer energizes the solenoid valve to provide the ON time cleaning pulse for the diaphragm valve and repeats this cycle until the system is shut down. The timer can also be wired for on demand cleaning with an external pressure switch. If this option is selected, the high and low limit pressure switch relays will be connected to the TB2 corresponding terminals. Otherwise, the common and high limit terminals on TB2 are jumpered to provide continuous operation.

Note: If the collector was supplied with an electrical control panel, the wiring diagram supplied with the control panel takes precedence over the general diagrams shown in this manual.

Input
102-132V/50-60Hz/1Ph

Output Solenoids
2-3A max per channel

Pulse ON Time
Factory set at 100-milliseconds, or 1/10-second.

NOTICE

Do not adjust pulse ON time unless the proper test equipment is available. Too much or too little ON time can cause shortened filter life.

Pulse OFF Time
Factory set at 10-seconds, the OFF time must be field adjusted such that the pressure at the air reservoir peaks at 7.5-psig just before the next pulse. Make final adjustments by observing the LOAD ON light flashing on the timer.

NOTICE

Open the valve to the air reservoir gauge only when adjusting OFF time.

Operating Temperature Range
-20° F to 130° F

Solenoid Valves
120V/60 Hz intermittent duty @ 20.9 watts

Interlocking
To ensure proper operation of the system the main blower should not start unless the cleaning mechanism, positive-displacement blower, and dust removal system are all operating. It is recommended that an interlock device is installed between these motors. Failure of interlocked devices should generally not shut down the main blower, but should activate an alarm system, if available. Failure of either a rotary airlock or screw conveyor with separate drives should shut down all other drives and alarm the operator. This will avoid filling the collector with dust.

Time Delay, Start-Up
Starting motors at 3-second intervals is recommended to minimize inrush current and to allow interlocking.

Time Delay, Shut-Down
A sequenced shut down approach is recommended for optimal performance of the collector. After the main blower shuts down, the remaining components should continue to run for several minutes to empty the hopper and dust removal system of all dust that drops from the filter bags after the primary airflow stops.

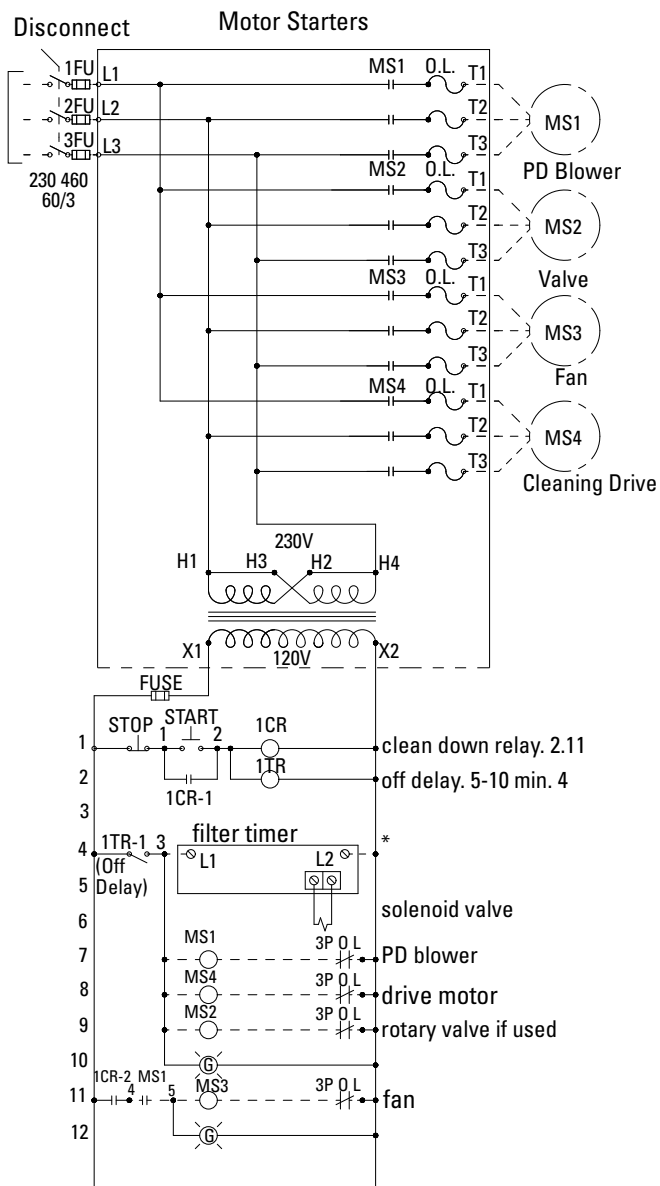

*1 TR-1 allows cleaning system to operate 5-10 minutes after fan stops

Use wiring diagram provided with collector, if provided

Typical Wiring Diagram

Felt Bag and Cage with Boltsafe™ Hardware Filter Installation

1. Slide the filter bag onto the filter cage until the top edge of the bag reaches the top flange of the filter cage.

Note: Place the bottom seam of the bag parallel to the long side of the oval.

2. From the clean-air plenum, insert the filter bag and filter cage assembly through the tubesheet aligning the two bolts with the two threaded inserts factory installed in the tubesheet.
3. Secure with Boltsafe bolts provided.

NOTICE

Hand-start each bolt before tightening either bolt. Do not use a power or impact driver to tighten bolts. A speed wrench using a maximum of 20 ft/lb is recommended.

Pleated Bag with Boltsafe™ Hardware Filter Installation

1. From the clean air plenum, insert pleated bag assembly through the tubesheet aligning the two bolts with the threaded inserts in the tubesheet. It may be necessary to squeeze the pleated bag as it is inserted into the tubesheet.
2. Secure with Boltsafe bolts provided.

NOTICE

Hand-start each bolt before tightening either bolt. Do not use a power or impact drive to tighten bolts. A speed wrench using a maximum of 20 ft/lb is recommended.

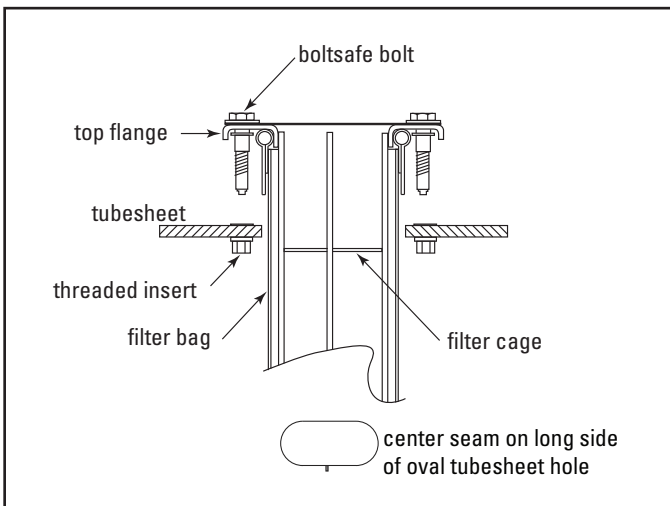

Felt Bag and Cage and Pleated Bag with Boltsafe Hardware Filter Installation

Pleated Bag with Snap-In Design Filter Installation

1. Slowly lower the filter through the tubesheet hole. Squeezing the filter to get the straps through the tubesheet may be required.



Push the opposite side of the top of the filter until it is securely snapped into the tubesheet hole.



2. Gently push the flexible urethane top of the filter on one side until it snaps into the tubesheet hole.



Note: A snapband retainer has been shipped for each filter. If you do not have these snapband retainers, call your Donaldson representative immediately so they can be sent to you for proper installation.

3. Pinch the snapband retainer in the center to form a figure "8".



4. Bend the loop slightly and place the retainer under the molded lip of the top flange of the filter. This shallow lip prevents upward movement of the snapband retainer after proper installation. With the snapband retainer held against one side of the filter top interior, slowly allow the retainer to expand into the recessed area between the lip rim and the four interior post stops.

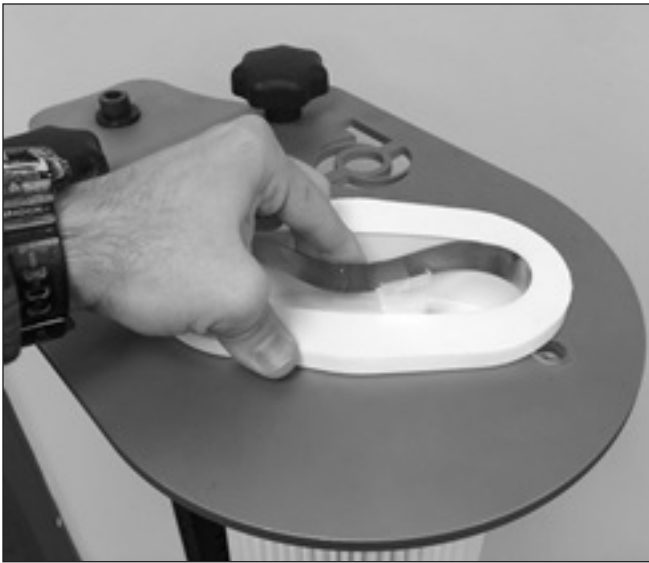

5. The snapband retainer should fit snugly between the lip rim and the vertical post stops. Be sure the snapband retainer is level and not installed crooked. A correctly installed snapband retainer will help prevent any potential leakage at the tubesheet and keep the filter firmly in place.

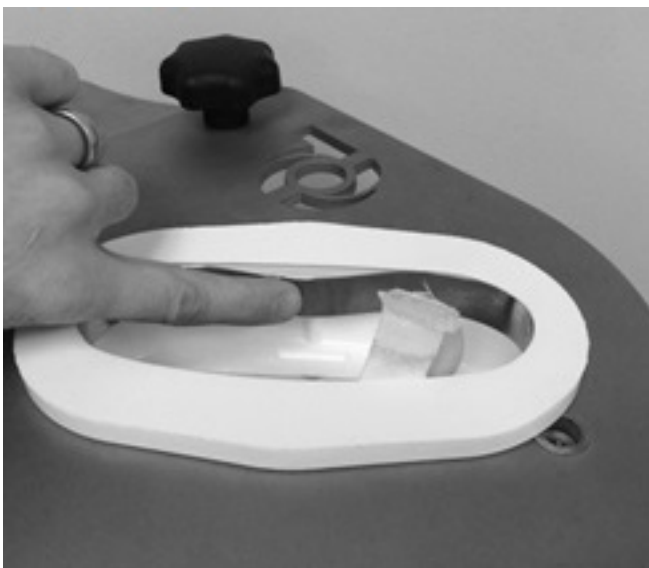
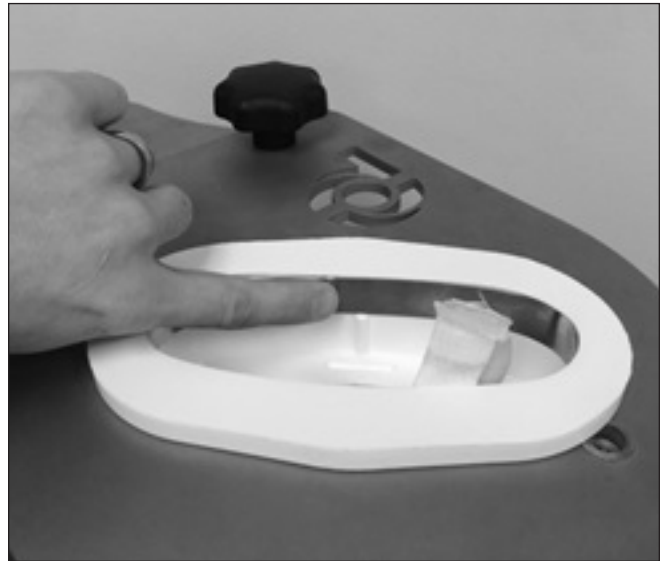

Felt Snap-In Bag Filter Installation

1. From the clean-air plenum, carefully insert the snap-in filter bag aligning the seam with the long edge of the oval in the tube sheet.
2. Snap the bag in place with the tube sheet between the upper and lower rings on the filter bag collar.
3. Slide the filter cage into the filter bag and seat firmly.

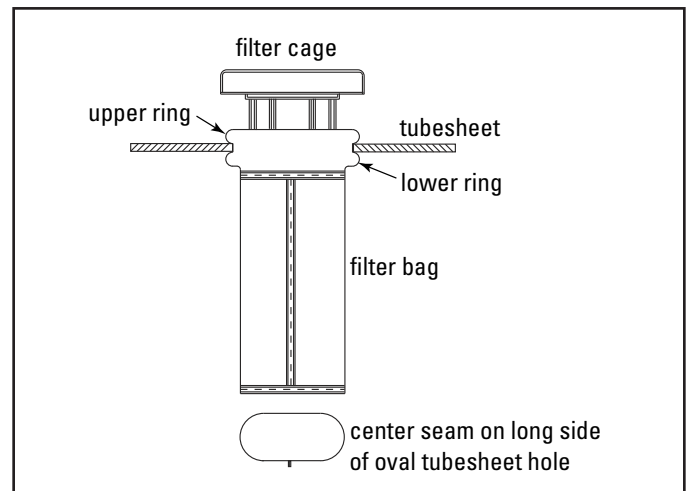

Felt Snap-In Bag Filter Installation

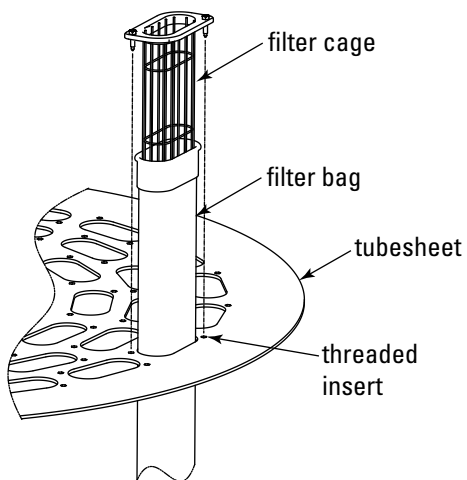

Bag and Cage with Boltsafe Hardware

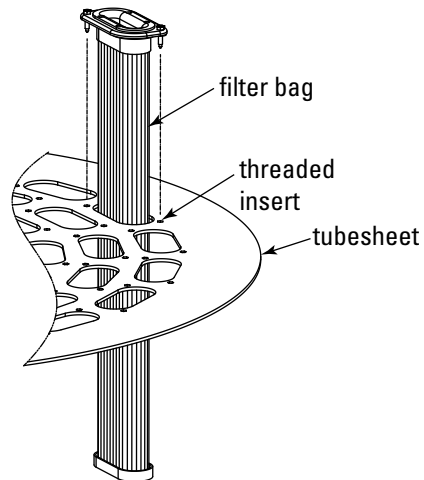

Pleated Bag with Boltsafe Hardware

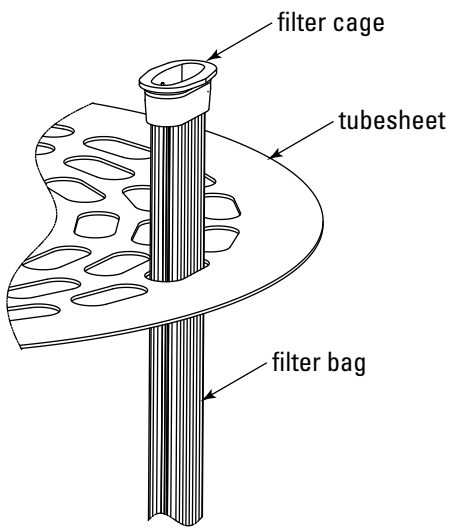

Pleated Bag Snap-In

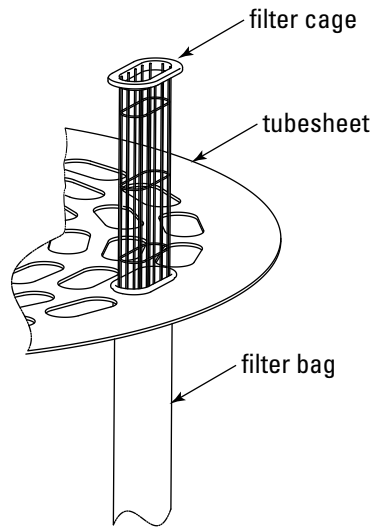

Felt Bag Snap-In

Filter Bag Installation

Preliminary Start-Up Check

Instruct all personnel on safe use and maintenance procedures.

CAUTION

Electrical work during installation, service or maintenance must be performed by a qualified electrician and comply with all applicable national and local codes.

Turn power off and lock out all power before performing service or maintenance work.

Check that the collector is clear and free of all debris before starting.

Do not install in classified hazardous atmospheres without an enclosure rated for the application.

1. Check all electrical connections for tightness and contact.
2. Check for proper rotation on all motors as described below.
To reverse rotation, single-phase power supply:
Follow manufacturer's instructions on the motor's nameplate.

To reverse rotation, three-phase power supply:
Switch any two leads on the motor junction box.

CAUTION

Do not look into fan outlet to determine rotation. View the fan rotation through the back of the motor.

Check that the exhaust plenum is free of tools or debris before checking blower/fan rotation.

Stand clear of exhaust to avoid personal injury.

Do not interchange a power lead with the ground wire. Severe personal injury and/or property damage may result.

3. All access panels should be sealed and secure.

4. Check that the hopper discharge gate is open and the storage container is properly sealed, if equipped
5. Check that the fan exhaust damper is set to the fully-closed position.
6. Check and remove all loose items in or near the inlet and outlet of the collector.
7. Check that all remote controls and solenoid enclosures (if applicable) are properly wired and all service switches are in the OFF position.
8. Check that all optional accessories are installed properly and secured.
9. Turn power ON at source.
10. Turn the cleaning air blower ON.
11. Adjust fan airflow with the exhaust damper.

NOTICE

Excess airflow can shorten filter life, cause electrical system failure and fan motor failure.

12. Check arm rotation by observing from outside the collector with main fan and positive displacement pump locked out.

13. The cleaning arm drive has been adjusted and tested at the factory and no additional adjustment should be required. The manifold drive should rotate smoothly and the manifold arms should be level with the tubesheet during rotation, with the bottom of the nozzles located approximately 1-3 inches above the tubesheet. However, misalignment can occur during shipment and installation of the collector. If this is the case, disconnect power to the drive assembly as described above, remove the master chain link on the gear reducer drive chain and rotate the manifold assembly by hand checking for binding or misalignment. Using a level, check the air tank mounting surface in both directions making sure it is level and parallel to the tube sheet. Correct any lateral misalignment by loosening the air tank hold down bolts on top of the

H-frame and re-centering the air tank using the slotted holes. If the air tank is not parallel to the tube sheet, adjust the 4 leveling screws under the air tank cross beam supports. Make sure to tighten the leveling screw lock nuts when finished. See Cleaning Arm Adjustment for location of the leveling screws. Retighten and check the manifold again by rotating it one complete revolution. The manifold nozzle height can be adjusted by using the slotted holes on the manifold arms. Once everything is readjusted, reconnect the master link on the chain drive.

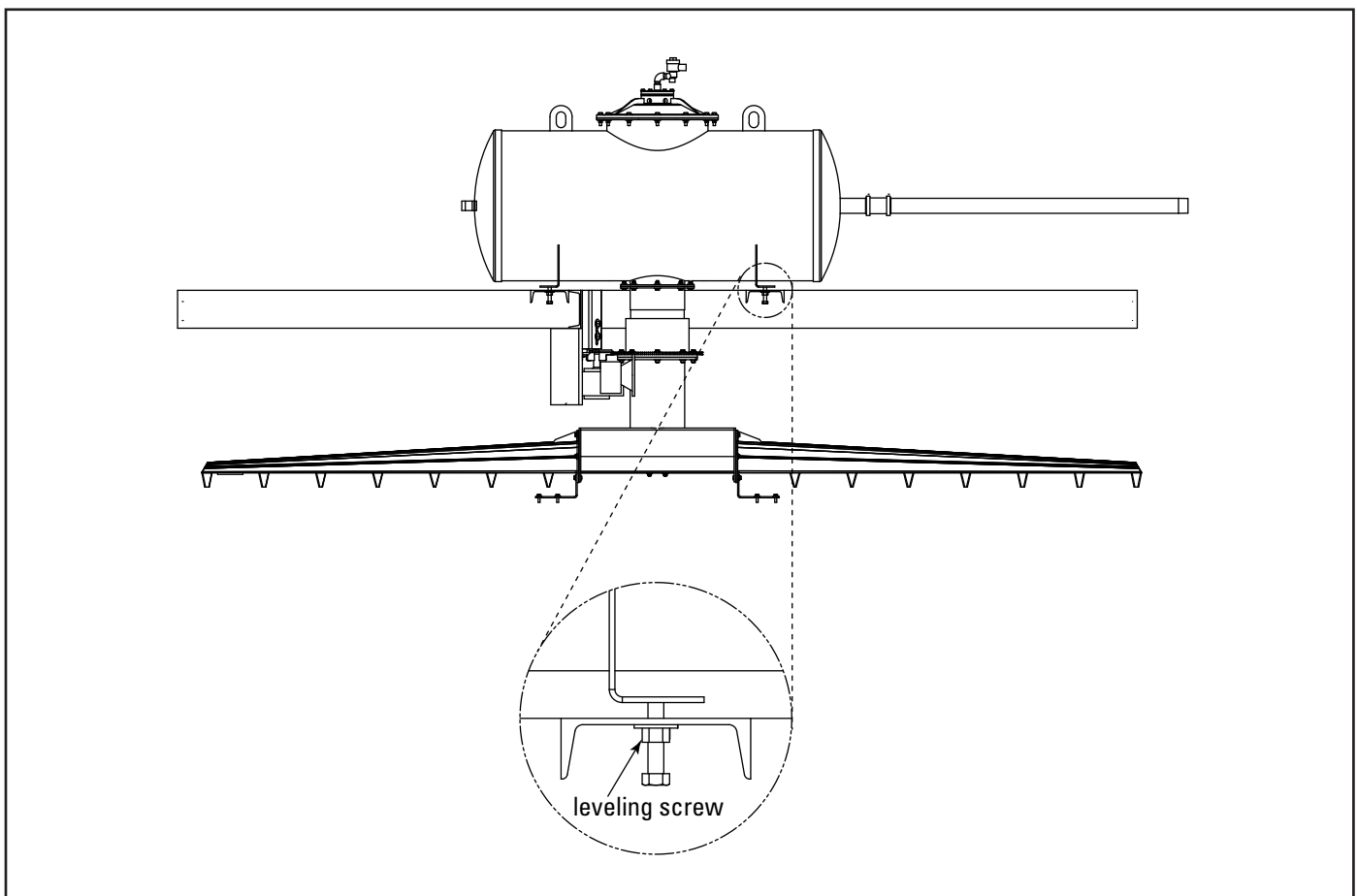

Cleaning Arm Adjustment

Operation

Start-Up

1. Start the positive-displacement cleaning blower and check for proper blower rotation.
2. Turn power to timer and solenoid ON.
3. Check solenoid and diaphragm valve operation.
4. Adjust the timer to allow the cleaning system pressure to rise to 7.5-psig between pulses. Too short of an OFF time results in inadequate cleaning pressure; too long of an OFF time will result in the pressure relief valve discharging cleaning air.
5. Close the isolation petcock between the positive-displacement blower and the gauge.
6. Start the system as shown in Start-Up Sequence.
7. Adjust fan for proper airflow with the volume control damper, if equipped.
8. Measure initial pressure drop across the tube sheet and filter bags during normal process operation with dust actively generated. Pressure drop will gradually rise until an equilibrium pressure drop is achieved, generally 3 to 4 "wg for seasoned filters, although anything between 1 to 6 "wg is considered normal.

Start-Up/Shut-Down Sequences

The recommended sequences for motor start-up and shut-down are outlined below. These sequences assure minimal material build-up in the hopper of the collector.

NOTICE

Not following these sequences can adversely impact the life of the filters and may result in equipment damage.

Start-Up Sequence

1. Pneumatic conveyor or transfer blower, if equipped.
2. Rotary airlock and screw conveyor - start simultaneously.
3. Manifold drive and pulse timer.
4. Positive-displacement cleaning blower.
5. Main blower.

Shut-Down Sequence

1. Main blower.
2. Positive-displacement cleaning blower.
3. Manifold drive and pulse timer.
4. Rotary airlock and screw conveyor - shut-down simultaneously.
5. Pneumatic conveyor or transfer blower, if equipped.

Maintenance Information

Instruct all personnel on safe use and maintenance procedures.



Use proper equipment and adopt all safety precautions needed for servicing equipment.

Use appropriate access equipment and procedures. Note the standard collector is not equipped with access platforms unless noted on the specification drawings.

Electrical service or maintenance work must be performed by a qualified electrician and comply with all applicable national and local codes.

Turn power off and lock out all power before performing service or maintenance work.

Do not install in classified hazardous atmospheres without an enclosure rated for the application.

Turn positive displacement pump OFF and bleed lines and tank before performing service or maintenance work.

Operational Checklist

1. Monitor the physical condition of the collector and repair or replace any damaged components.

Routine inspections will minimize downtime and maintain optimum system performance. This is particularly important on continuous-duty applications.

2. Periodically check the positive displacement pump components and replace filters as required to maintain blower pressure rating. Check rotation of cleaning arms.
3. Monitor pressure drop across filters.

Abnormal changes in pressure drop may indicate a change in operating conditions and possibly a fault to be corrected.

4. Monitor exhaust.
5. Monitor dust disposal.

Weekly

1. Check that pressure drop is within normal operational range (from 1 to 6 "wg).
2. Check for proper air pressure at reservoir (7.5-psig).
3. Check for proper lubricant level in positive-displacement blower. Reference the positive displacement blower owner's manual.
4. Check positive displacement blower inlet air filter to see how dirty it is. Clean blower intake filter by using a commercial cleaner such as Oakite and water. Dry thoroughly and immerse in SAE 30 engine oil. Drain off excess oil and reassemble. Do not use gasoline to clean blower intake filter due to possible explosion.

Quarterly

1. Check condition of the clean-air plenum. If dust accumulation is present, check filter bags for wear, tears or loose seals. Replace as necessary.
2. On high inlet collectors, check the condition of the removable baffle weld assembly by removing the side access cover on the baffle housing. Replace significantly worn baffle assemblies to prevent damage to the filter tubes and housing section.
3. Check solenoid and diaphragm valve operation.
4. Check door seals and replace as necessary.
5. Check cleaning arm drive chain and positive-displacement blower belt tension.
6. Check positive-displacement blower and gear reducer oil levels. Add oil through breather mounting holes or other oil fill locations. Reference the blower owner's manual for proper lubricant.
 - 0°F-32°F - use ISO 68 lubricant
 - 32°F-90°F - use ISO 100 lubricant
 - 90°F-120°F - use ISO 150 lubricant
7. Inspect explosion vents, if applicable, for signs of wear or cracks.
8. Check the rotating arm manifold drive gear reducer oil level. Add oil through breather mounting holes or other oil fill locations. The gear reducer is filled with synthetic oil. See reducer manual for recommended lubrication type and quantity. When checking or replacing the oil, make sure to check both housings of the double reduction reducer. Each housing has its own vent, fill and drain plug.

Inlet Baffle Assembly Replacement

1. Shut down the system following the recommended Shut Down sequence found in this manual.
2. Wear appropriate protective clothing, safety glasses, dust masks, etc. to avoid contact with hazardous dust if applicable.
3. Following all installation and hoisting precautions found in this manual, remove the top cover perimeter bolts and use a crane to lift and remove the assembly.
4. Inspect the baffle housing for wear and repair or replace as required.
5. Clean the top of the housing and re-apply sealer to the perimeter opening as required.
6. Carefully hoist and install the new baffle assembly into the baffle housing. When the assembly is lowered into the housing, it will be guided into a vertical position by the side angle rails and lower bottom guides attached to the housing. The baffle spacer plate will be on or just above the two side support gussets when properly installed.
7. Tighten bolts, start system, and inspect for leaks.

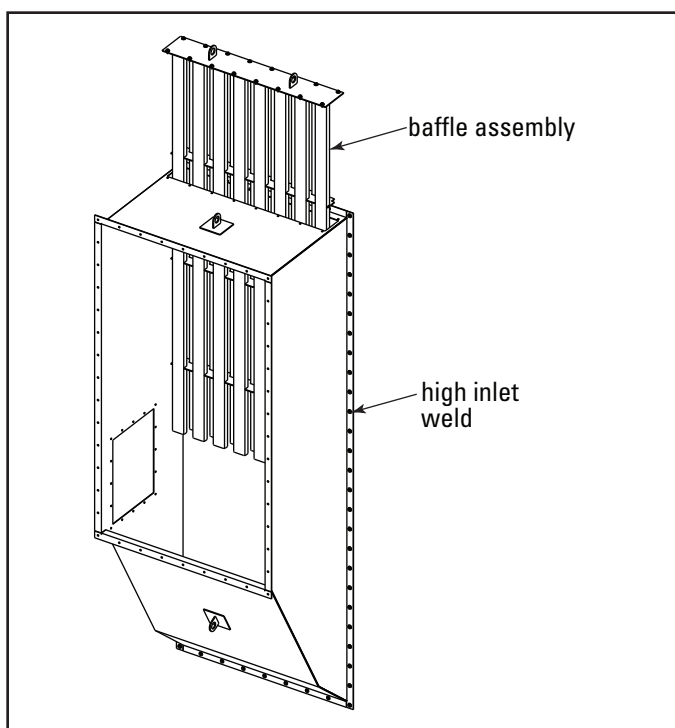

Baffle Assembly Installation

Filter Removal and Installation



Use proper safety and protective equipment when removing contaminants and filters.

Dirty filters may be heavier than they appear.

Use care when removing filters to avoid personal injury and/or property damage.

Turn power off and lock out all power before performing service or maintenance work.

Do not operate with missing or damaged filters.

NOTICE

To access bags under the cleaning manifold arm, it is necessary to remove the chain on manifold drive sprocket to rotate pulse arms for bag and cage removal.

Felt Bag and Cage with Boltsafe Hardware Filter Removal

1. Properly shutdown the system and lock out electrical system.
2. Access clean air plenum through door.
3. Loosen bolts (2) from each filter cage flange.
4. Remove cage leaving the bag suspended in dirty air plenum.
5. Push the bag through the tubesheet into the dirty air plenum.
6. Repeat steps 4-6 for each bag.
Note: The cleaning arm may need to be manually rotated to access some bags.
7. Remove all dirty bags through hopper access door.

Felt Bag and Cage with Boltsafe™ Hardware Filter Installation

1. Slide the filter bag onto the filter cage until the top edge of the bag reaches the top flange of the filter cage.

Note: Place the bottom seam of the bag parallel to the long side of the oval.

2. From the clean-air plenum, insert the filter bag and filter cage assembly through the tubesheet aligning the two bolts with the two threaded inserts factory installed in the tubesheet.
3. Secure with Boltsafe bolts provided.

NOTICE

Hand-start each bolt before tightening either bolt. Do not use a power or impact driver to tighten bolts. A speed wrench using a maximum of 20 ft/lb is recommended.

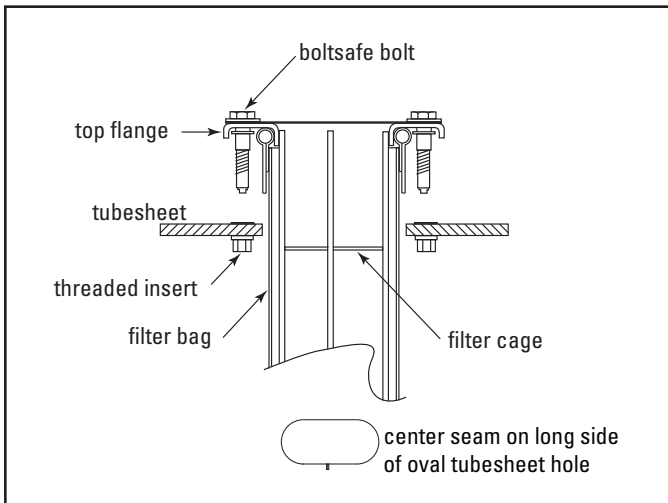

Felt Bag and Cage and Pleated Bag with Boltsafe Hardware Filter Installation

Pleated Bag with Boltsafe™ Hardware Filter Removal

1. Properly shutdown the system and lock out electrical system.
2. Access clean air plenum through door.
3. Unscrew bolts (2) from each pleated bag.
4. Remove pleated bag.

Pleated Bag with Boltsafe™ Hardware Filter Installation

1. From the clean air plenum, insert pleated bag assembly through the tubesheet aligning the two bolts with the threaded inserts in the tubesheet. It may be necessary to squeeze the pleated bag as it is inserted into the tubesheet.
2. Secure with Boltsafe bolts provided.

NOTICE

Hand-start each bolt before tightening either bolt. Do not use a power or impact drive to tighten bolts. A speed wrench using a maximum of 20 ft/lb is recommended.

Pleated Bag with Snap-In Design Filter Removal

1. Properly shutdown the system and lock out electrical system.
2. Access clean air plenum through door.
3. Grab snap band finger loop to remove the snap band and discard. The replacement filter comes with a new snap band.
4. Squeeze the flange of the molded top at the center of the straight-a-ways of the oval. While doing so, rock and lift to release the molded tops from the tubesheet.
5. Lift the filter out of the tubesheet.

Pleated Bag with Snap-In Design Filter Installation

1. Slowly lower the filter through the tubesheet hole. Squeezing the filter to get the straps through the tubesheet may be required.

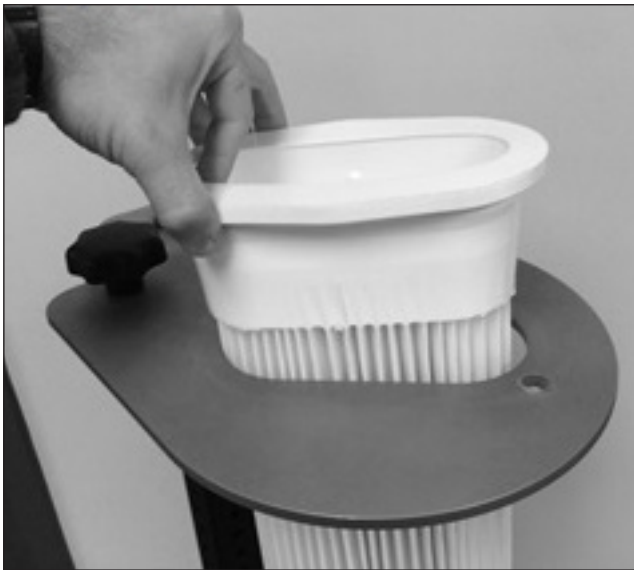

2. Gently push the flexible urethane top of the filter on one side until it snaps into the tubesheet hole.



Push the opposite side of the top of the filter until it is securely snapped into the tubesheet hole.



Note: A snapband retainer has been shipped for each filter. If you do not have these snapband retainers, call your Donaldson representative immediately so they can be sent to you for proper installation.

3. Pinch the snapband retainer in the center to form a figure "8".



4. Bend the loop slightly and place the retainer under the molded lip of the top flange of the filter. This shallow lip prevents upward movement of the snapband retainer after proper installation. With the snapband retainer held against one side of the filter top interior, slowly allow the retainer to expand into the recessed area between the lip rim and the four interior post stops.



5. The snapband retainer should fit snugly between the lip rim and the vertical post stops. Be sure the snapband retainer is level and not installed crooked. A correctly installed snapband retainer will help prevent any potential leakage at the tubesheet and keep the filter firmly in place.

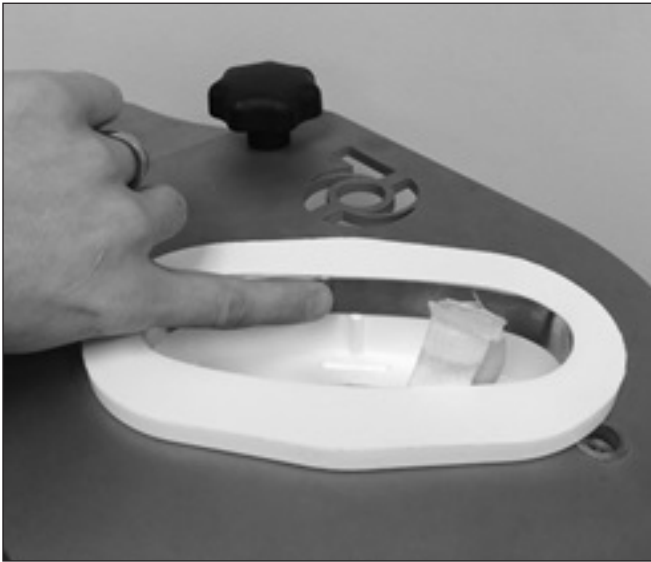

Felt Snap-In Bag Filter Removal

1. Properly shutdown the system and lock out electrical system.
2. Access clean air plenum through door.
3. Remove cage leaving the bag hanging in dirty air plenum.
4. Push one side of snap band to deform and release from the tube sheet.
5. Push the bag down into the bottom of the dirty air plenum.
6. Repeat steps 4-6 for each bag.
Note: The cleaning arm may need to be manually rotated to access some bags.
7. Remove all dirty bags through hopper access door.

Felt Snap-In Bag Filter Installation

1. From the clean-air plenum, carefully insert the snap-in filter bag aligning the seam with the long edge of the oval in the tube sheet.
2. Snap the bag in place with the tube sheet between the upper and lower rings on the filter bag collar.
3. Slide the filter cage into the filter bag and seat firmly.

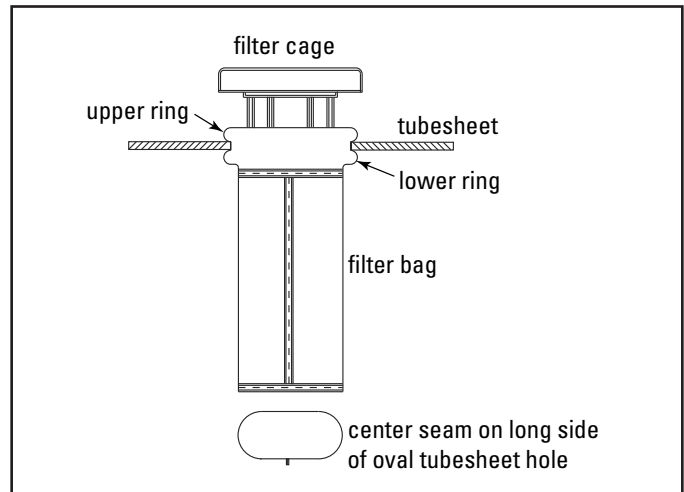

Felt Snap-In Bag Filter Installation

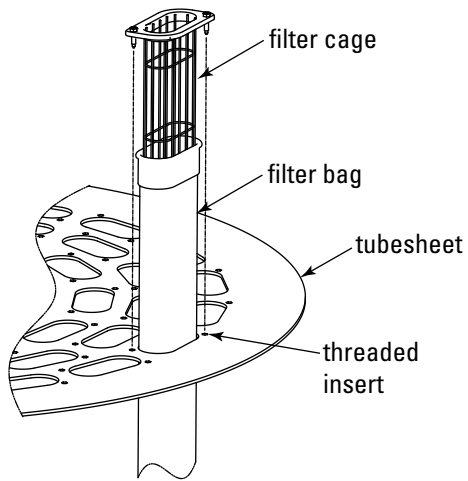

Bag and Cage with Boltsafe Hardware

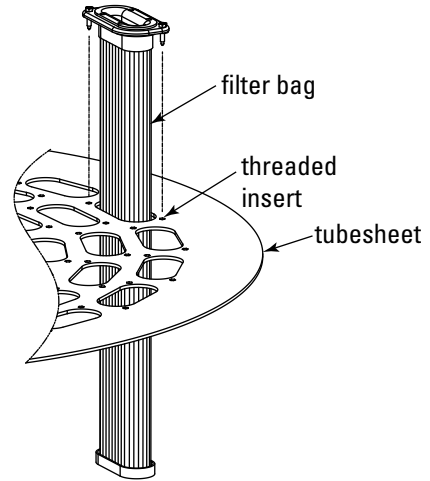

Pleated Bag with Boltsafe Hardware

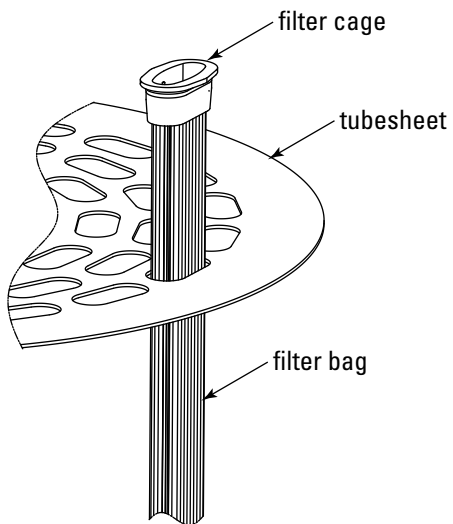

Pleated Bag Snap-In

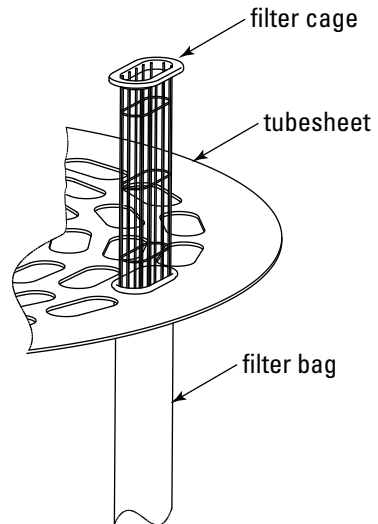

Felt Bag Snap-In

Filter Bag Installation

Optional Equipment

Plant Air Kit

In place of the positive displacement cleaning blower, plant air can be used for the filter tube cleaning system. The plant air must be clean, dry, and filtered to prevent any oil or water from entering the cleaning system. An optional plant air kit is available to control the flow and regulate the pressure of the customer's plant air. In addition, optional coalescing and particulate filters can be provided with this kit.

Reference the plant air manifold kit drawing shipped with the collector for installation instructions.

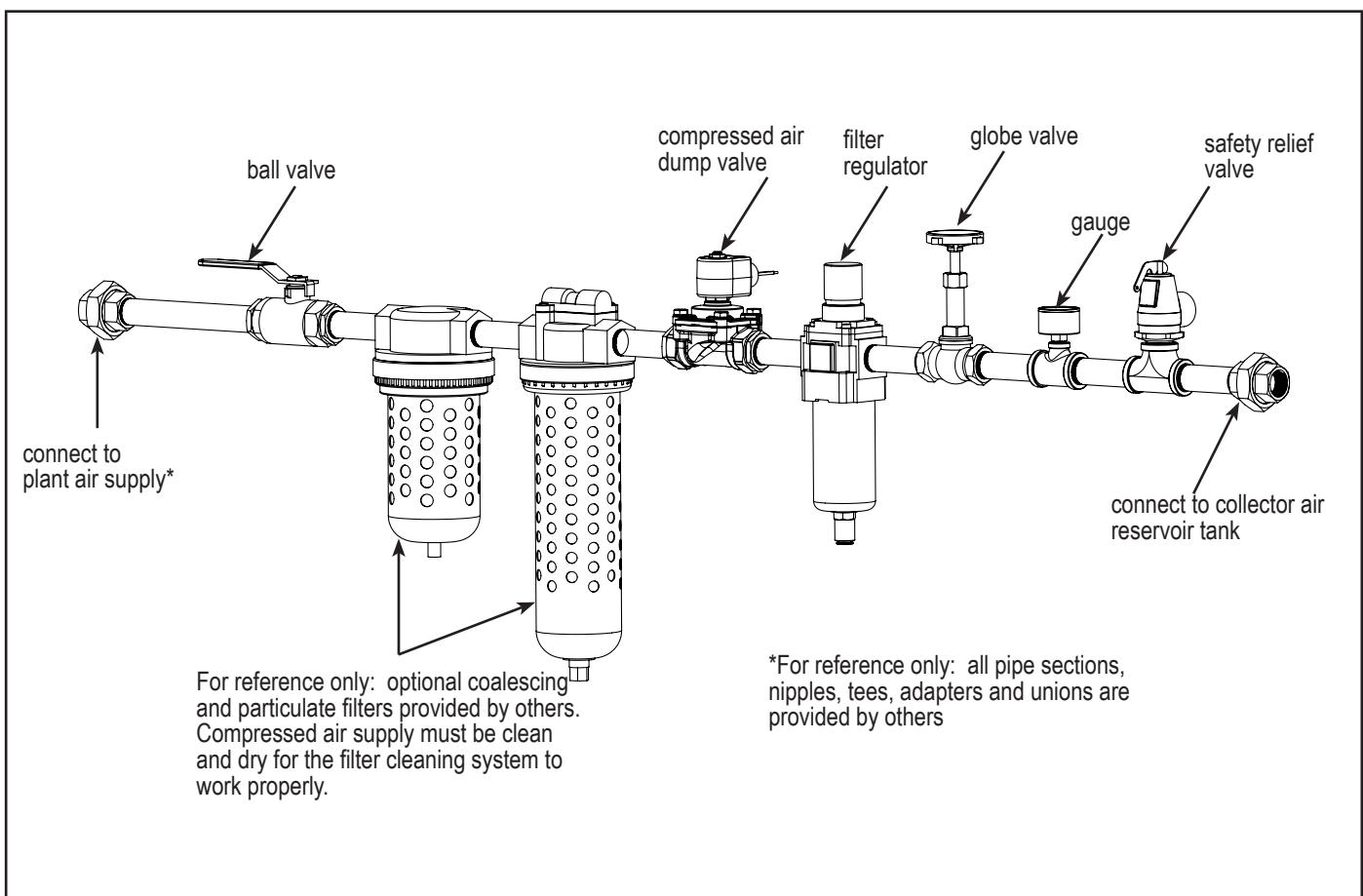

Optional Plant Air Kit

Magnehelic® Gauge

The Magnehelic is a differential pressure gauge used to measure the pressure difference between the clean-air and dirty-air plenums and provides a visual display of filter change requirements. The high-pressure tap is located in the dirty-air plenum and the low-pressure tap is located in the clean-air plenum.

1. Choose a convenient, accessible location on or near the collector for mounting that provides the best visual advantage.
2. Plug the pressure ports on the back of the gauge using two, 1/8-in NPT pipe plugs supplied. Install two, 1/8-in NPT male adapters supplied with the gauge into the high- and low-pressure ports on the side of the gauges.
3. Attach the mounting bracket using three, #6-32 x 1/4-in screws supplied.
4. Mount the gauge and bracket assembly to the supporting structure using two, self-drilling screws.
5. Thirty-five feet of plastic tubing is supplied and must be cut in two sections. Connect one section of tubing from the gauge's high-pressure port to the pressure fitting located in the dirty-air plenum. Connect remaining tubing from the gauge's low-pressure port to the fitting in the clean-air plenum. Additional tubing can be ordered from your representative.
6. Zero and maintain the gauge as directed in the manufacturer's Operating and Maintenance Instructions provided.

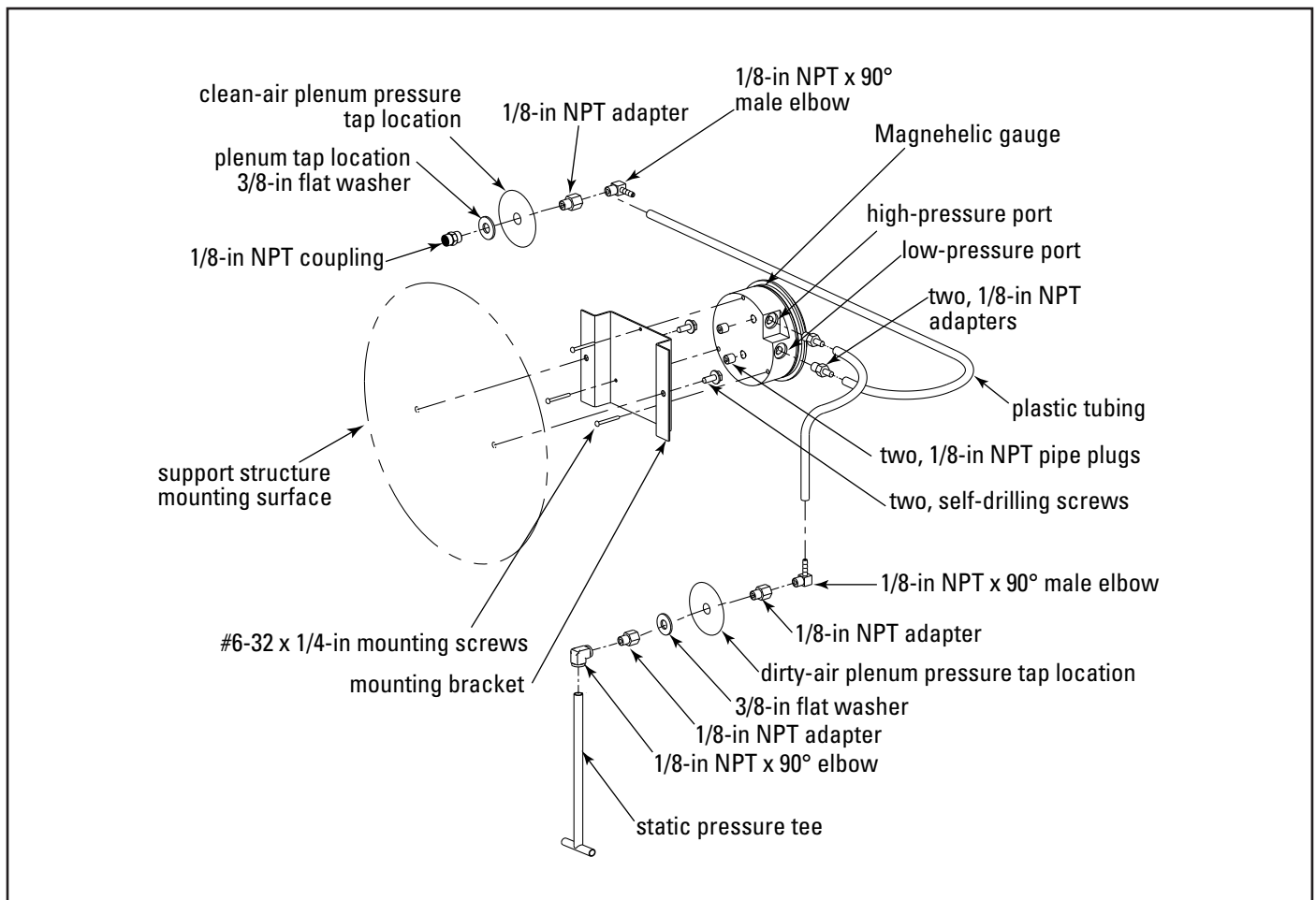

Magnehelic Gauge Installation

Photohelic® Gauge

CAUTION

Electrical installation, service, or maintenance work must be performed by a qualified electrician and comply with all applicable national and local codes.

Turn power off and lock out all power before performing service or maintenance work.

Do not install in classified hazardous atmospheres without an enclosure rated for the application.

The Photohelic combines the functions of a differential pressure gauge and a pressure-based switch. The gauge function measures the pressure difference between the clean-air and dirty-air plenums and provides a visual display of filter condition. The high-pressure tap is located in the dirty-air plenum and a low-pressure tap is located in the clean-air plenum. The pressure-based switch function provides high-pressure ON and low-pressure OFF control of the filter cleaning system.

1. Choose a convenient, accessible location on or near the collector for mounting that provides the best visual advantage.
2. Mount the gauge to the remote panel or door using the mounting ring, retaining ring, and four #6-32 x 1 1/4-in

screws. Do not tighten screws. Connect two, 1/8-in NPT x 1/4-in OD male adapters to the gauge's high- and low-pressure ports. Tighten screws.

3. On the back of the gauge, remove four #6-32 x 5/16-in screws and plastic enclosure. Set aside. Add two jumper wires supplied by customer. Remove the jumper from the pressure switch located on the timer board, if equipped. Using the 3/4-in conduit opening, wire the gauge as shown. Reassemble and fasten enclosure securely.
4. Thirty-five feet of plastic tubing is supplied and must be cut in two sections. Connect one section of tubing from the gauge's high-pressure port to the pressure fitting located in the dirty-air plenum. Connect remaining tubing from the gauge's low-pressure port to the fitting in the clean-air plenum. Additional tubing can be ordered from your representative.
5. Zero and maintain the gauge as directed in the manufacturer's Operating and Maintenance Instructions provided.
6. To install the Photohelic Gauge mounted in a NEMA 4, Weatherproof Enclosure, follow Steps 4 and 5.

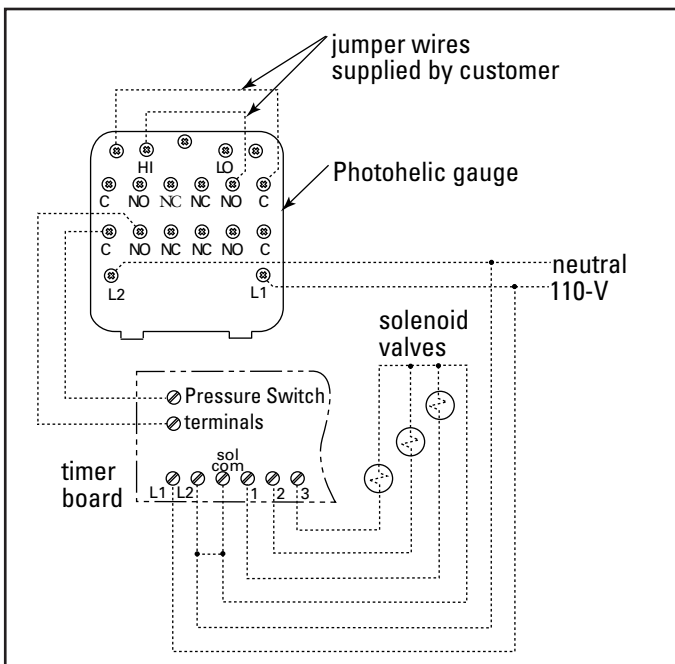

Photohelic Gauge Wiring Diagram

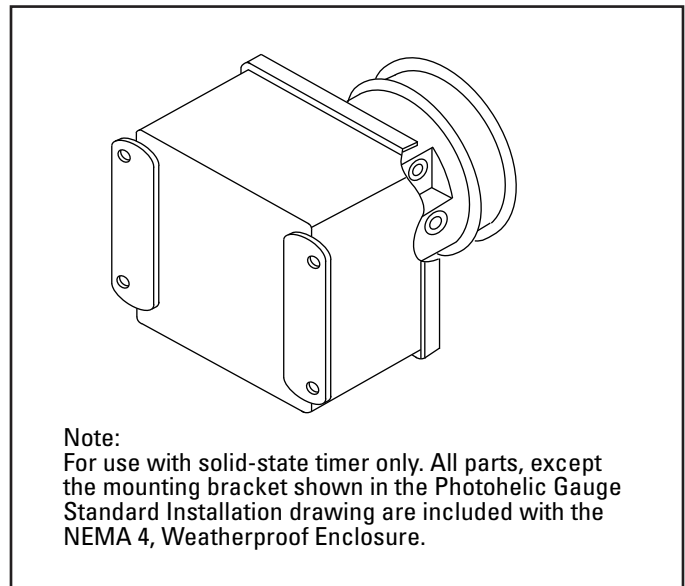

Photohelic Gauge in Optional NEMA 4 Weatherproof Enclosure

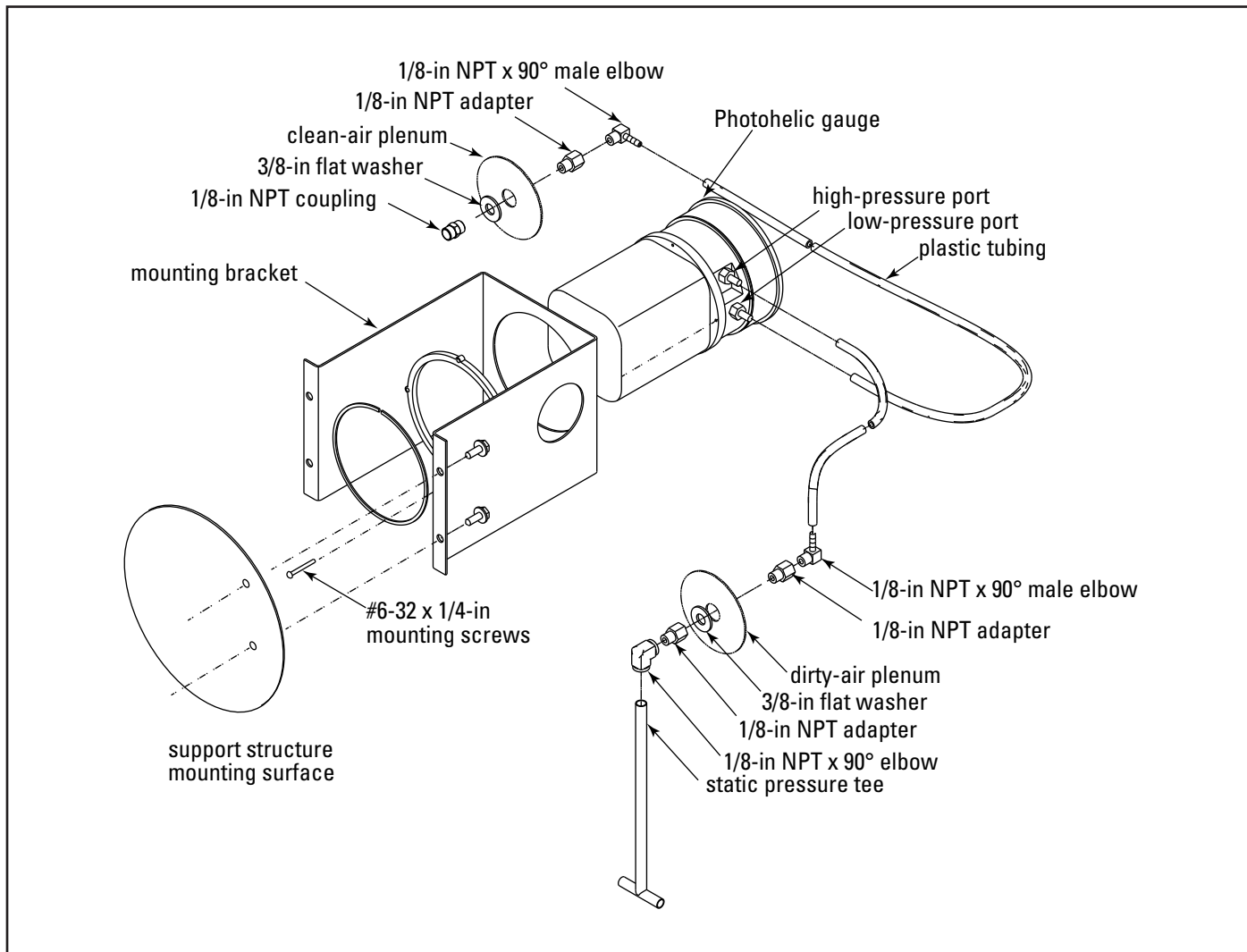

Photohelic Gauge Installation

Explosion Vent



Personal injury, death, and/or property damage can result from material discharge during venting.

The material discharged during the venting of an explosion must be safely directed outdoors away from areas occupied by personnel to reduce risk of personal injury and/or property damage.

The risk of personal injury and/or property damage can be minimized or avoided by locating vented equipment outside buildings and away from normally occupied areas.

Explosion vents should be inspected regularly to confirm physical and operational condition. Replace any damaged parts immediately.

Standard explosion vents are intended for outdoor installations only.

Unless otherwise noted, the explosion venting calculations are based on formulas from NFPA-68 for outdoor applications only, with no duct or obstructions on the explosion vent panel.

Contact Donaldson Torit for assistance in calculating specific venting requirements for equipment.

NFPA 68 can provide guidance on both the frequency of and appropriate details for inspections.

Troubleshooting

Problem	Probable Cause	Remedy
Fan blower and motor do not start	Improper motor wire size	Rewire using the correct wire gauge as specified by national and local codes.
	Not wired correctly	Check and correct motor wiring for supply voltage. See motor manufacturer's wiring diagram. Follow wiring diagram and the National Electric Code.
	Collector not wired for available voltage	Correct wiring for proper supply voltage.
	Input circuit down	Check power supply to motor circuit on all leads.
	Electrical supply circuit down	Check power supply circuit for proper voltage. Check for fuse or circuit breaker fault. Replace as necessary.
	Damaged motor	Replace damaged motor.
Fan blower and motor start, but do not stay running	Incorrect motor starter installed	Check for proper motor starter and replace if necessary.
	Access doors are open or not closed tight	Close and tighten access doors. See Filter Installation.
	Damper control not adjusted properly	Check airflow in duct. Adjust damper control until proper airflow is achieved and the blower motor's amp draw is within the manufacturer's rated amps.
	Electrical circuit overload	Check that the power supply circuit has sufficient power to run all equipment.
Clean-air outlet discharging dust	Filters not installed correctly	See Filter Installation.
	Filter damage, dents in the end caps, gasket damage, or holes in media	Replace filters as necessary. Use only genuine Donaldson replacement parts. See Filter Installation.
Insufficient airflow	Fan rotation backwards	Check rotation arrow on fan housing and make sure fan is rotating in direction indicated.
	Access doors open or not closed tight	Check that all access doors are in place and secured. Check that the hopper discharge opening is sealed and that dust container is installed correctly.
	Fan exhaust area restricted	Check fan exhaust area for obstructions. Remove material or debris. Adjust damper flow control.
	Filters need replacement	Remove and replace using genuine Donaldson replacement filters. See Filter Removal and Installation.

Problem	Probable Cause	Remedy
Insufficient airflow continued	Pulse cleaning not energized	Use a voltmeter to check the solenoid valve. Make sure the solenoid valve exhaust port weather cap is removed.
	Solenoid valve failure, constant air leakage	Replace solenoid valve. Lock out all electrical power to the collector and bleed the compressed air system before removing the valve.
	Solenoid valve failure, failure to open	Check voltage output from Solid-State Timer. If output voltage is present, replace the solenoid valve. Lock out all electrical power to the collector and bleed the compressed air system before removing the valve. Make sure the solenoid valve exhaust port weather cap is removed.
	Diaphragm valve failure	Lock out all electrical power to the collector and bleed the compressed air system before any component repair work is completed. Replace the primary and secondary diaphragms and springs. Note: To check or replace the large diaphragm, remove the smaller secondary diaphragm as described below. Remove the valve body cover screws and then the diaphragm. When reassembling the large diaphragm, use a screw driver or punch to hold the center of the diaphragm against the housing seat before re-tightening the cover bolts. To reassemble the smaller secondary diaphragm, remove the solenoid valve and pipe fittings and push down on the top of the diaphragm to hold it in the closed position while tightening the retaining bolts.
	Solid-State timer failure	Using a voltmeter, check supply voltage to the timer board. Check and replace the fuse on the timer board if necessary. If the fuse is good and input power is present but output voltage to the solenoid is not, replace the timer board. See Solid-State Timer Installation.
	Solid-State timer out of adjustment	See Solid-State Timer and Solid-State Timer Wiring Diagram.

Troubleshooting

Problem	Probable Cause	Remedy
Pulse cleaning never stops	Pressure switch not wired to the timer board correctly	Connect the pressure switch on the timer board to Terminals 7 and 8 on TB3 on the Torit Delta P Controller (if used).
	Pressure switch terminals on the timer board jumpered	Remove jumper wire on Solid-State Timer board before wiring to the timer.
	High Pressure On or Low Pressure Off setpoint not adjusted for system conditions	Adjust setpoints to current conditions.
	Pressure tubing disconnected, ruptured, plugged, or kinked	Check tubing for kinks, breaks, contamination, or loose connections.
Alarm light is ON	Alarm setpoint too low	Adjust to a higher value.
	Excess pressure drop	Check cleaning system and compressed air supply. Replace filters if filters do not clean down.
	Pressure tubing disconnected, ruptured, plugged, or kinked	Check tubing for kinks, breaks, contamination, or loose connections.
Cleaning light is ON, but cleaning system not functioning	Improper wiring	Check wiring between the timer board and between the timer board and solenoid valve coils.
	Defective solenoids	Check all solenoid coils for proper operation.
	Timer board not powered	Check power ON light on timer board's LED display. If not illuminated, check the supply voltage to the timer board. Check the fuse on the timer board. Replace if necessary.
	Timer board defective	If LED is illuminated, observe the output display. Install a temporary jumper across the pressure switch terminals. Output levels should flash in sequence. Check output using a multimeter set to 150-Volt AC range. Measure from SOL COM to a solenoid output. The needle will deflect when LED flashes for that output if voltage is present. If LED's do not flash, or if no voltage is present at output terminals during flash, replace the board.
Drive manifold not rotating	Misaligned or broken chain. Worn drive bushing.	Check drive chain and tensioner for proper alignment/tension. If chain is broken, remove and check manually. Check rotation for binding and alignment as explained in Preliminary Start-Up Check.

Product Information (Process Owner to complete and retain for your records)

Model Number _____	Serial Number _____
Ship Date _____	Installation Date _____
Filter Type _____	
Collected Dust _____	
Dust Properties: Kst _____	Pmax _____ MIE _____ MEC _____
Accessories _____	
Other _____	

Donaldson Industrial Air Filtration Warranty

Donaldson warrants to the original purchaser only that the Goods will be free from defects in material and manufacture for the applicable time periods stated below: (1) Major structural components for a period of ten (10) years from the date of shipment; (2) Non-Structural, Donaldson-built components and accessories including Donaldson Airlocks, TBI Fans, TRB Fans, Fume Collector products, Donaldson built electrical control components, and Donaldson-built Afterfilter housings for a period of twelve (12) months from date of shipment; and (3) Donaldson-built filter elements for a period of eighteen (18) months from date of shipment.

Buyer is solely responsible for determining if goods fit Buyer's particular purpose and are suitable for Buyer's process and application. Seller's statements, engineering and technical information, and recommendations are provided for the Buyer's convenience and the accuracy or completeness thereof is not warranted. If, after Seller receives written notice, within the warranty period, that any goods allegedly do not meet Seller's warranty, and Seller, in its sole discretion, determines that such claim is valid, Seller's sole obligation and Buyer's exclusive remedy for breach of the foregoing warranty or any Seller published warranty, will be, at Seller's option, either: (i) repair or replacement of such goods or (ii) credit or refund to Buyer for the purchase price from Seller. In the case of repair or replacement, Seller will be responsible for the cost of shipping the parts but not for labor to remove, repair, replace or reinstall the allegedly defective goods. Refurbished goods may be used to repair or replace the goods and the warranty on such repaired or replaced goods shall be the balance of the warranty remaining on the goods which were repaired or replaced. Any repair or rework made by anyone other than Seller is not permitted without prior written authorization by Seller, and voids the warranty set forth herein. Seller warrants to Buyer that it will perform services in accordance with the Sales Documents using personnel of required skill, experience and qualifications and in a professional and workmanlike manner in accordance with generally recognized industry standards for similar services. With respect to any services subject to a claim under the warranty set forth above, Seller shall, in its sole discretion, (i) repair or re-perform the applicable services or (ii) credit or refund the price of such services at the pro rata contract rate and such shall be Seller's sole obligation and the exclusive remedy for breach of the foregoing warranty on services. Products manufactured by a third party ("Third Party Product") may constitute, contain, be contained in, incorporated into, attached to or packaged together with, the goods. Buyer agrees that: (a) Third Party Products are excluded from Seller's warranty in this Section 7 and carry only the warranty extended by the original manufacturer, and (b) Seller's liability in all cases is limited to goods of Seller's design and manufacture only. EXCEPT FOR SELLER'S WARRANTY OF TITLE TO THE GOODS, SELLER EXPRESSLY DISCLAIMS AND EXCLUDES ALL OTHER WARRANTIES WHATSOEVER, WHETHER, EXPRESSED OR IMPLIED, ORAL, STATUTORY, OR OTHERWISE, INCLUDING BUT NOT LIMITED TO MERCHANTABILITY, FITNESS FOR A PARTICULAR PURPOSE, NON-INFRINGEMENT OF THIRD PARTY INTELLECTUAL PROPERTY AND ANY WARRANTIES ARISING FROM TECHNICAL ADVICE OR RECOMMENDATIONS, COURSE OF DEALING OR OF PERFORMANCE, CUSTOM OR USAGE OF TRADE. Seller's obligations do not cover normal wear and tear or deterioration, defects in or damage to any goods resulting from improper installation, accident or any utilization, maintenance, repair or modification of the goods, or any use that is inconsistent with Seller's instructions as to the storage, installation, commissioning or use of the goods or the designed capabilities of the goods or that, in its sole judgment, the performance or reliability thereof is adversely affected thereby, or which is subjected to abuse, mishandling, misuse or neglect or any damage caused by connections, interfacing or use in unforeseen or unintended environments or any other cause not the sole fault of Seller, and shall be at Buyer's expense. Seller's warranty is contingent upon the accuracy of all information provided by Buyer. Any changes to or inaccuracies in any information or data provided by Buyer voids this warranty. Seller does not warrant that the operation of the goods will be uninterrupted or error-free, that the functions of the goods will meet Buyer's or its customer's requirements unless specifically agreed to, or that the goods will operate in combination with other products selected by Buyer or Buyer's customer for its use.

The terms of this warranty may only be modified by a special warranty document signed by a Director, General Manager or Vice President of Donaldson. To ensure proper operational performance of your equipment, use only genuine Donaldson replacement parts.

This Product is provided subject to and conditioned upon Donaldson's Terms of Sale ("Terms"), a current copy of which is located at termsofsale.donaldson.com. These Terms are incorporated herein by reference. By purchasing or using this Product, the user accepts these Terms. The Terms are available on our website or by calling our customer service line at 1-800-365-1331.

Significantly improve the performance of your collector with genuine Donaldson Torit replacement filters and parts. **Call Donaldson Torit at 800-365-1331.**

Important Notice

Many factors beyond the control of Donaldson can affect the use and performance of Donaldson products in a particular application, including the conditions under which the product is used. Since these factors are uniquely within the user's knowledge and control, it is essential the user evaluate the products to determine whether the product is fit for the particular purpose and suitable for the user's application. All products, product specifications, availability and data are subject to change without notice, and may vary by region or country.



Donaldson.

Donaldson Company, Inc.
Minneapolis, MN
donaldsonorit.com • shop.donaldson.com

North America
Email: donaldsonorit@donaldson.com
Phone: (USA): 800-365-1331 • (MX): 800-343-3639

Australasia
Email: marketing.australia@donaldson.com
Phone: +61 2 4350 2000
Toll Free: (AU) 1800 345 837 • (NZ) 0800 743 387
IOM 4011200 (ENG), Revision 19 (August 2020) ©2003 Donaldson Company, Inc. Donaldson, Torit, Boltsafe and the color blue are marks of Donaldson Company, Inc. All other marks belong to their respective owners.

China IAF
Email: info.cn@donaldson.com
Phone: (86) 400-820-1038

Donaldson Europe B.V.B.A.
Email: IAF-europe@donaldson.com
Phone: + 32 (0) 16 38 38 11

India
Email: marketing.India@donaldson.com
Phone: +91 124 4807400
Toll Free: 18001035018

Latinoamerica
Email: IndustrialAir@donaldson.com
Phone: +52 449 300 2442

South Africa
Email: SAMarketing@donaldson.com
Phone: +27 11 997 6000

Southeast Asia IAF
Email: IAF.SEA@donaldson.com
Phone: (65) 63117373